



Portail et portillon BA 311



# GAMME CLUB

CHOIX INTÉMPOREL

**Au fil du temps, la tradition du bois a été remplacée par la modernité de l'aluminium.**

La gamme Club respecte dans la plus pure authenticité le savoir-faire des menuisiers : assemblages rigides, combinaisons de profilés, insertion de décors...  
Le choix est immense, la personnalisation de rigueur.



environ 600  
RAL disponibles



RAL 7016  
givré

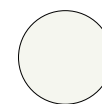

RAL 9010  
givré



RAL 7035  
givré



RAL 3004  
givré



RAL 5003  
givré



Noir 2100  
sablé



RAL 6005  
givré



Marron 0477  
givré



RAL 2900  
givré



RAL 9007  
givré



Noir BAZALT  
givré



NOUVEAU  
RAL 7039  
givré



OPTION +15%  
RAL 7040  
givré



OPTION +15%  
RAL 7037  
givré



OPTION +15%  
RAL 6021  
givré



Portail CS 211 en Brun 0477 G

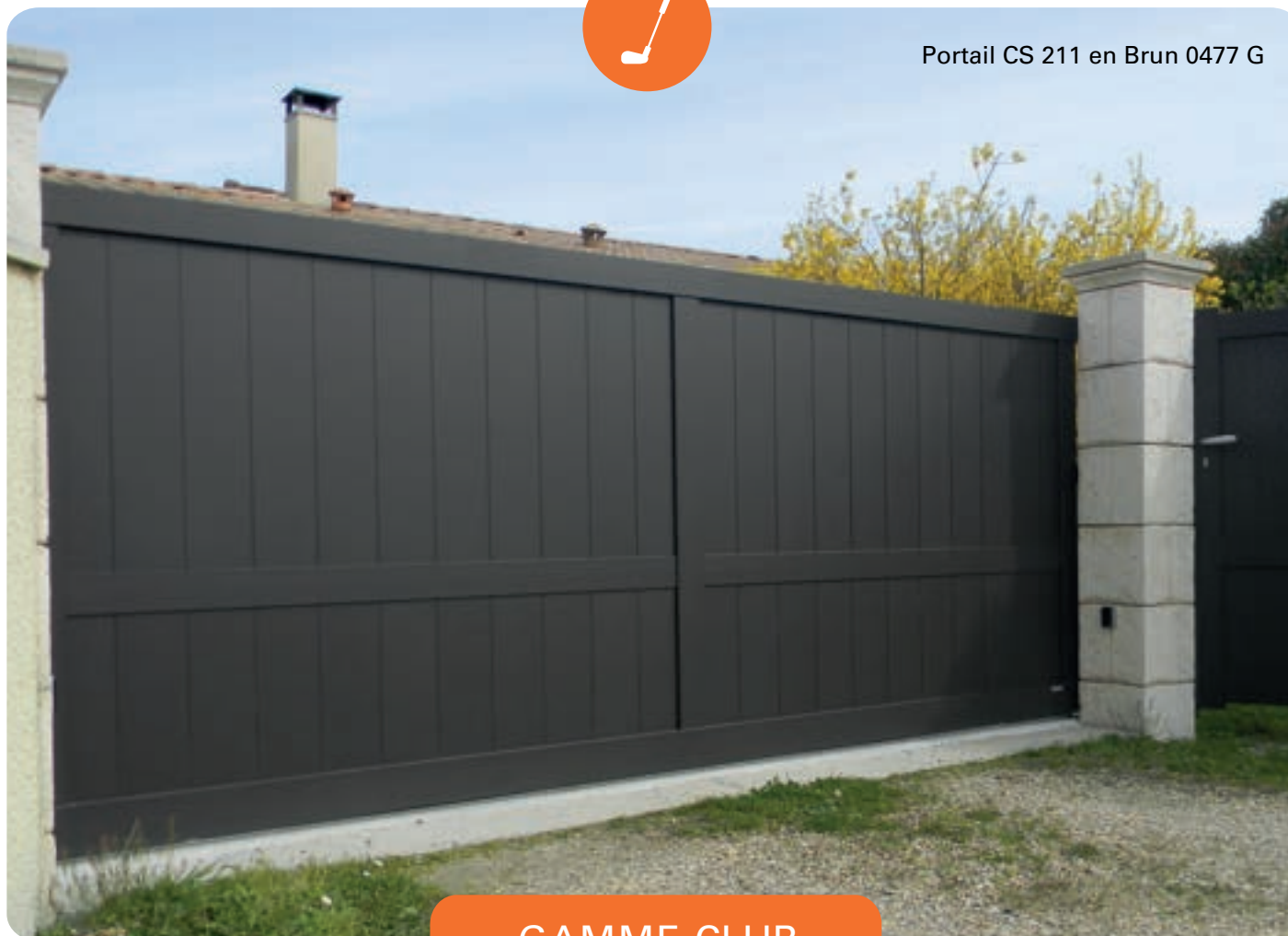

FABRIQUÉ  
EN FRANCE



GAMME CLUB

[closura.com](https://closura.com)

LAQUAGE  
GARANTI  
CLUB  
COLOR





BA : Battant



CS : Coulissant

MENUISIER



# TRUSQUIN

BA + CS

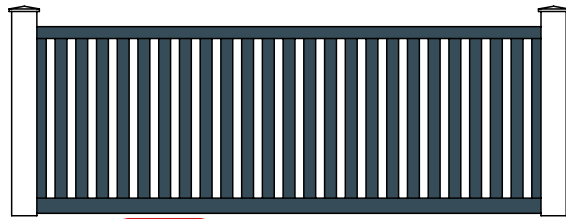

CS 101 **NOUVEAU** Réalisable en autoportant (p.164)

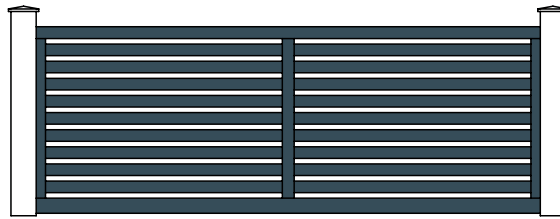

CS 108

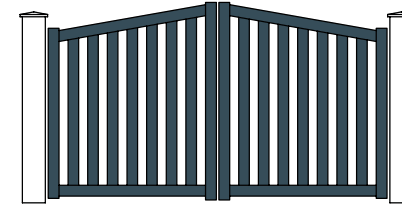

BA 102

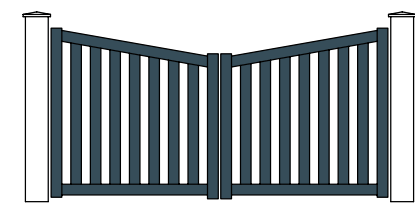

BA 103

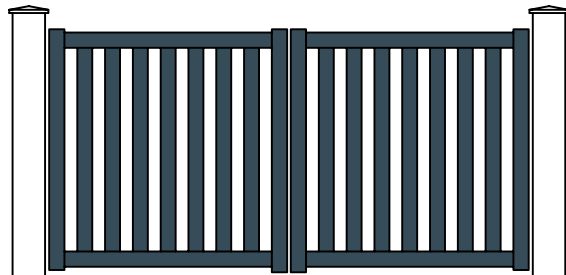

BA 101

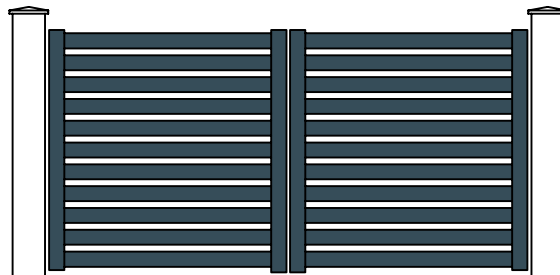

BA 108

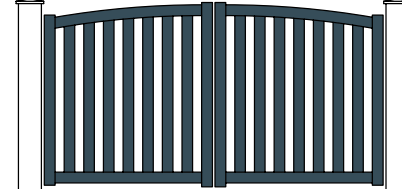

BA 104

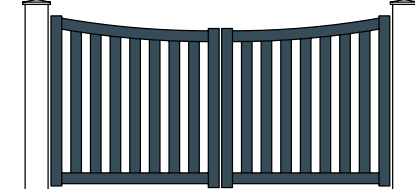

BA 105

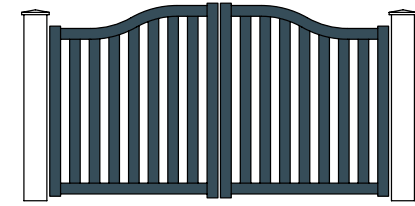

BA 106

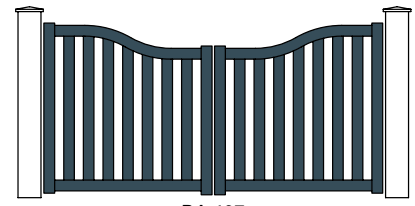

BA 107



Portail BA 101



Portail BA 108



BA : Battant



CS : Coulissant



CB : Coulissant aspect Battant

MENUISIER



# VARLOPE

BA + CS + CB

Portail BA 111 en Brun 0477 G



BA 118 / CS 118

NOUVEAU

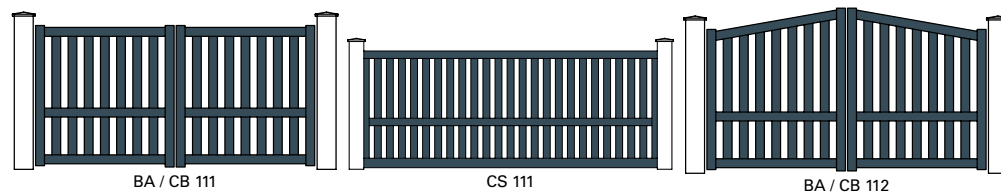
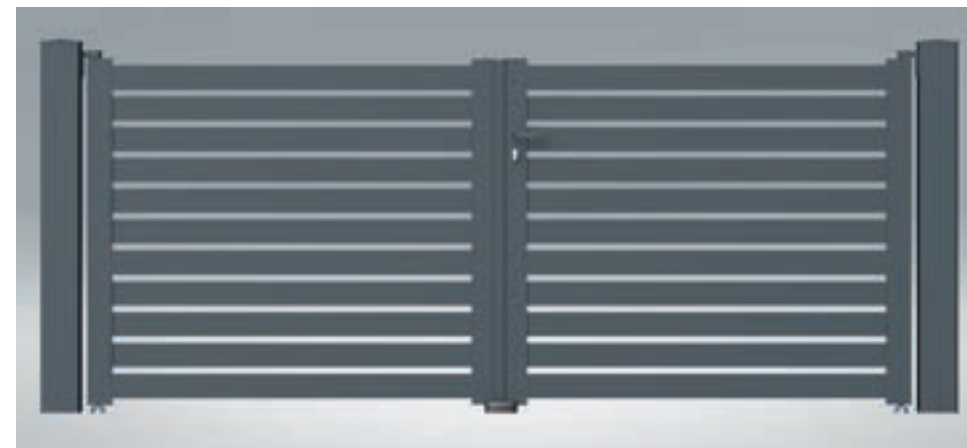

BA / CB 111

CS 111

BA / CB 112

BA 118

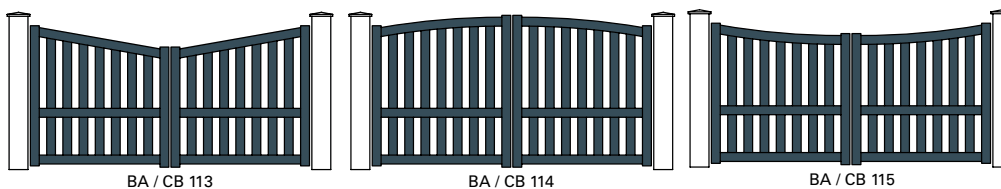

BA / CB 113

BA / CB 114

BA / CB 115



CS 118

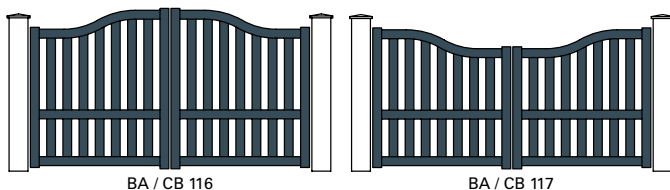

BA / CB 116

BA / CB 117



BA : Battant



CS : Coulissant

MENUISIER



## GOUGE

BA

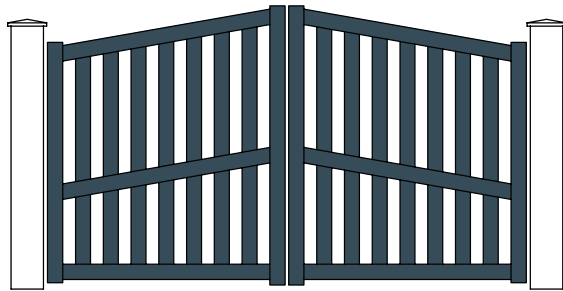

BA 122

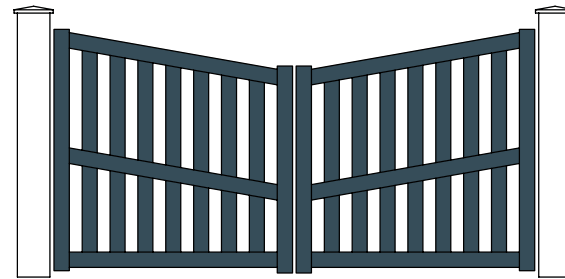

BA 123

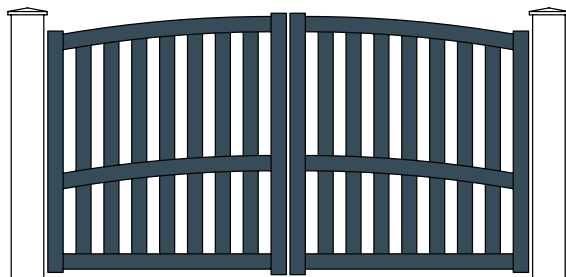

BA 124

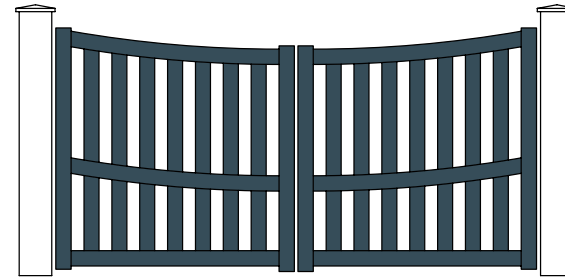

BA 125

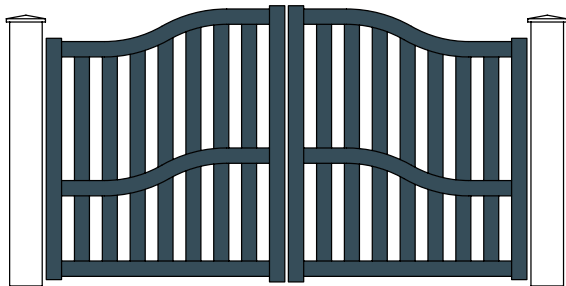

BA 126

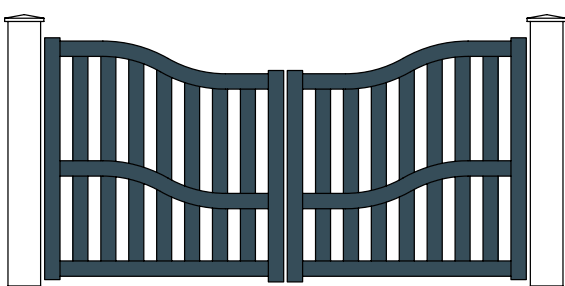

BA 127





BA : Battant



CS : Coulissant

MENUISIER



# GUIMBARDE

BA + CS

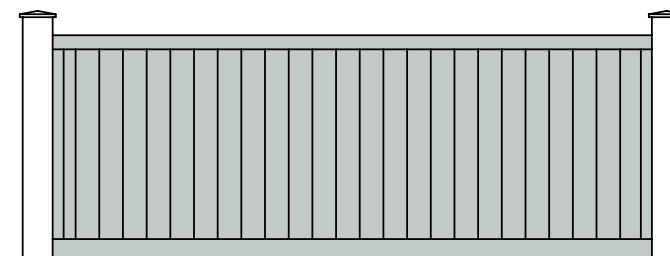

CS 201

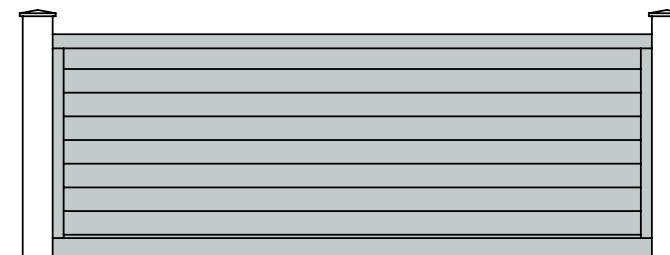

CS 208

**NOUVEAU** Réalisable en autoportant (p.165)

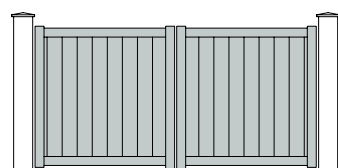

BA 201

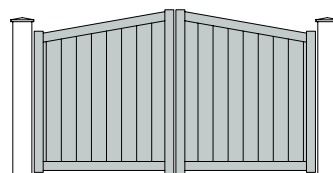

BA 202

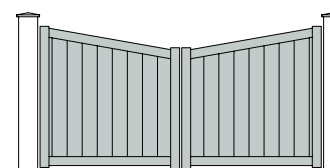

BA 203

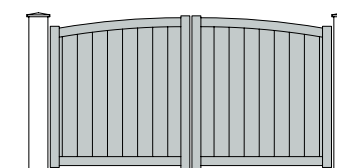

BA 204

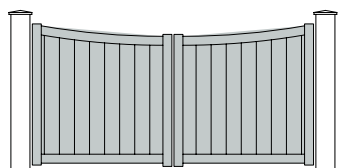

BA 205

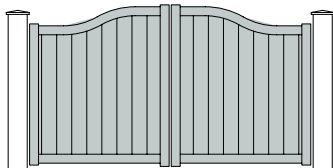

BA 206

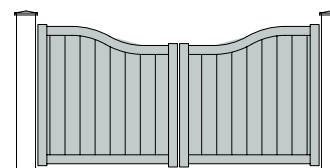

BA 207

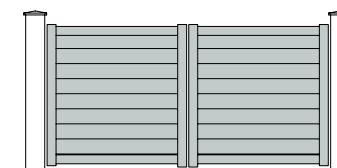

BA 208



Portail BA 201



Portail et portillon BA 214 en 9007 G





BA : Battant



CS : Coulissant



CB : Coulissant aspect Battant

MENUISIER



## RIFFLARD

BA + CS + CB

Portail CB 214

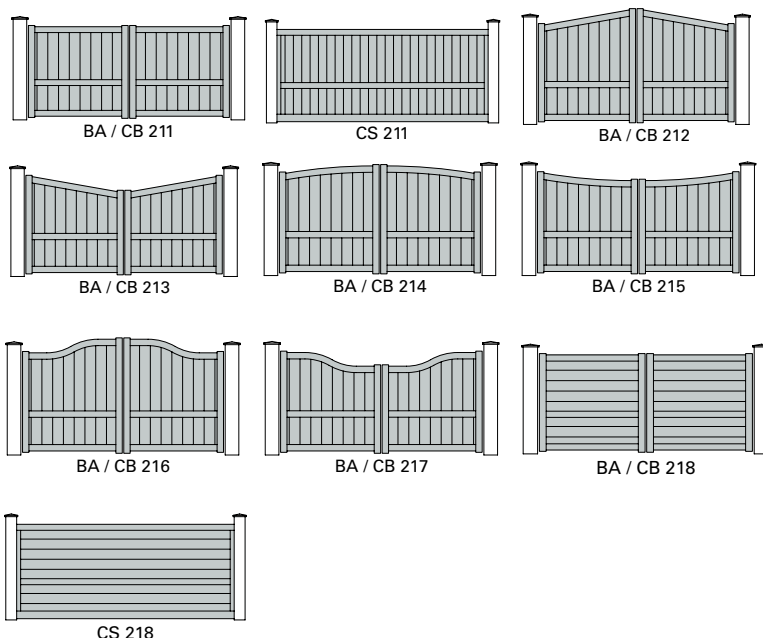

## HERMINETTE

BA

Portail BA 226 en Brun 0477 G

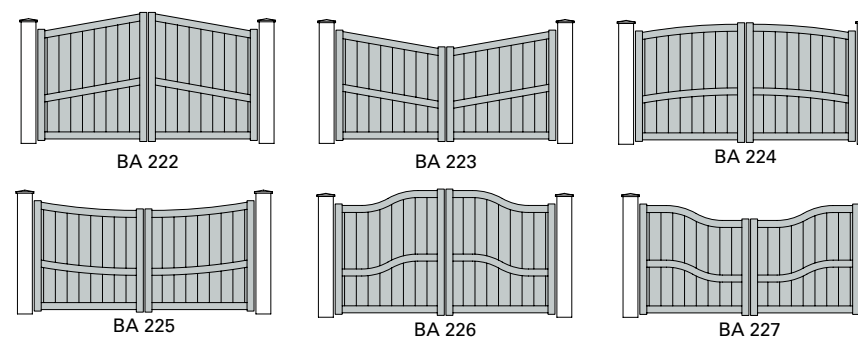



BA : Battant



CS : Couissant

MENUISIER

# VRILLE

Sens des lames fougères à préciser.

BA + CS

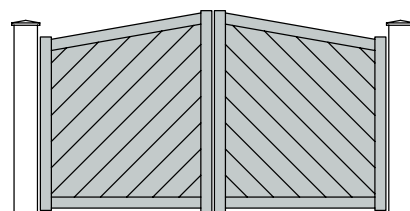

BA 232

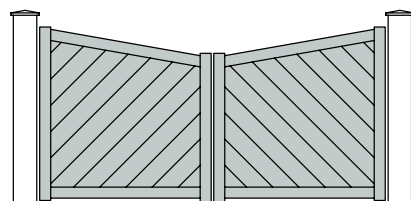

BA 233

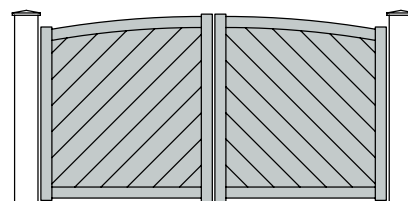

BA 234

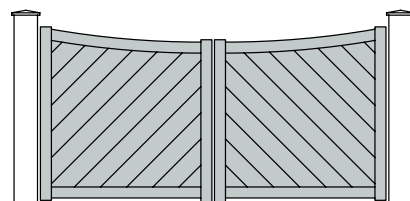

BA 235

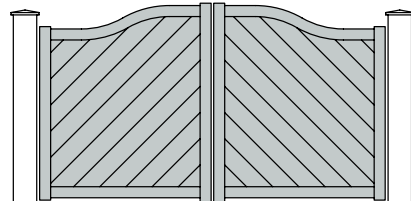

BA 236

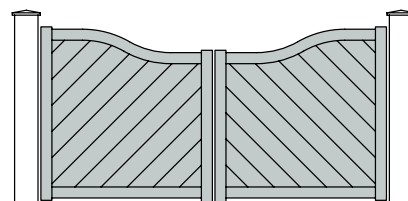

BA 237



Portail BA 231 en Brun 0477 G

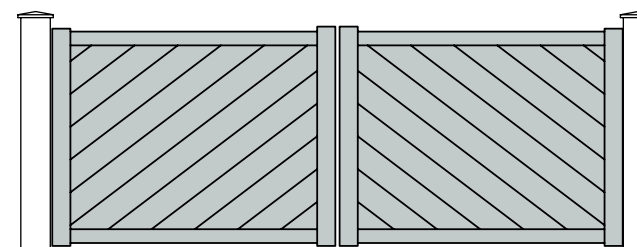

BA 231

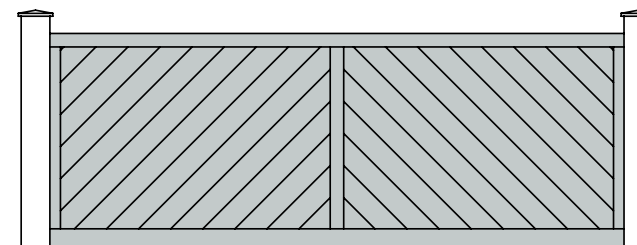

CS 231



BA : Battant



CS : Coulissant



CB : Coulissant aspect Battant

MENUISIER



## BÉDANE

BA + CS + CB

Sens des lames fougères à préciser.

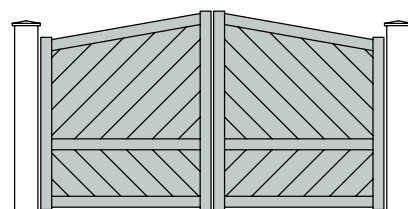

BA 242 / CB 242

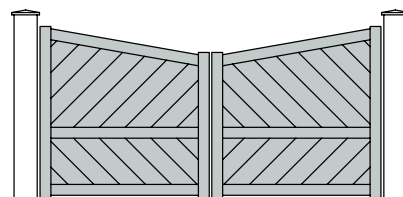

BA 243 / CB 243

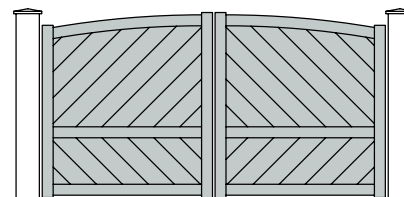

BA 244 / CB 244

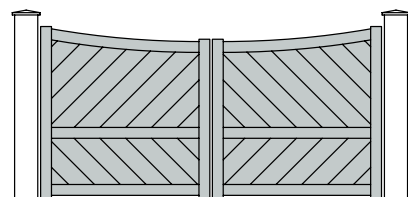

BA 245 / CB 245

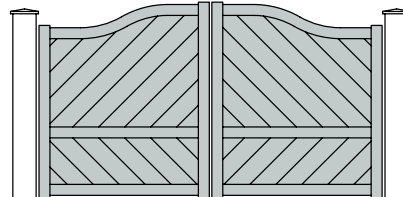

BA 246 / CB 246

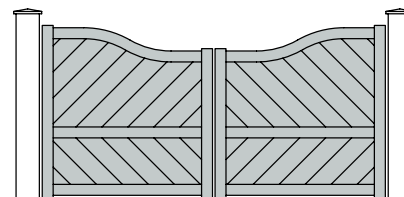

BA 247 / CB 247



Portail BA 241

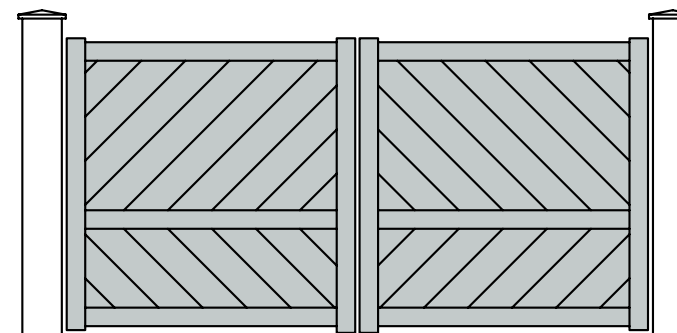

BA 241 / CB 241

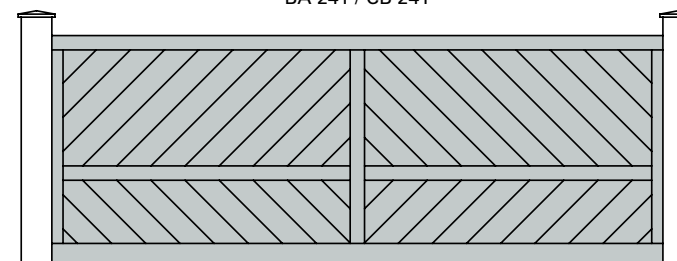

CS 241



BA : Battant



CS : Coulissant



CB : Coulissant  
aspect Battant

MENUISIER



## VILEBREQUIN

BA + CS + CB

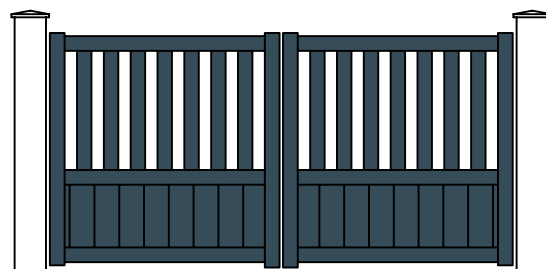

BA 311 / CB 311

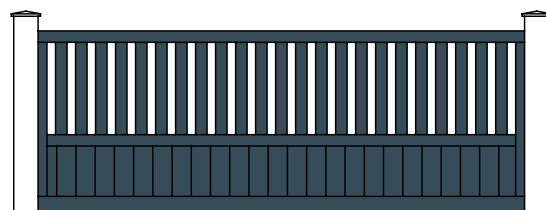

CS 311

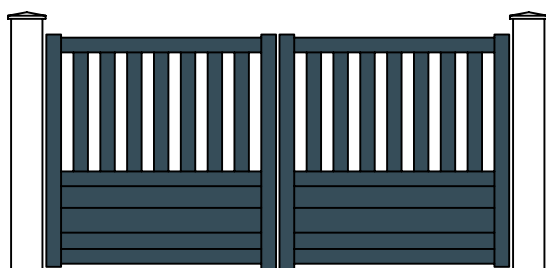

BA 318 / CB 318

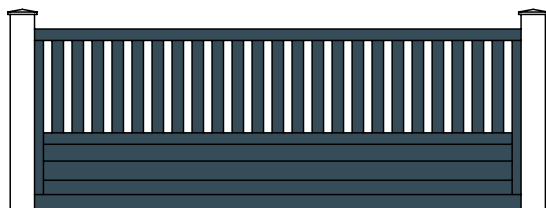

CS 318

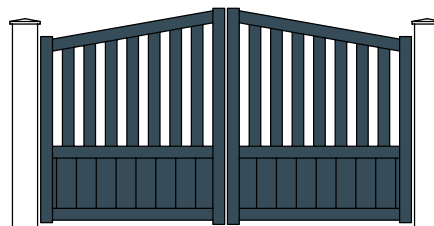

BA 312 / CB 312



BA 313 / CB 313

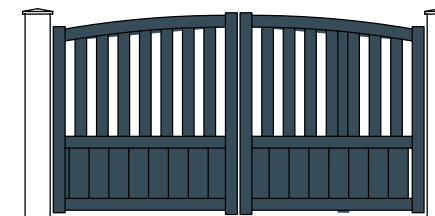

BA 314 / CB 314



BA 315 / CB 315

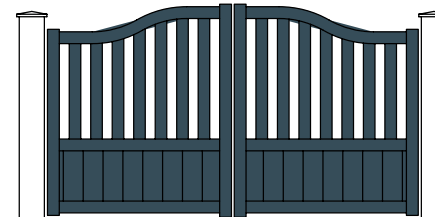

BA 316 / CB 316

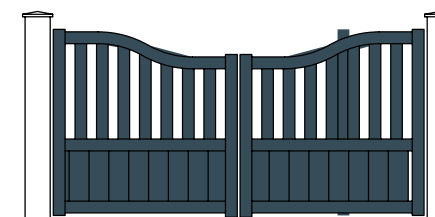

BA 317 / CB 317



Portail BA 311



BA : Battant



CS : Coulissant



CB : Coulissant aspect Battant

MENUISIER



## COMPAS

BA

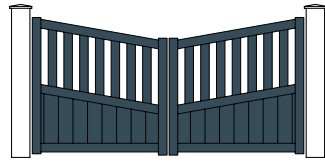

BA 323



BA 324

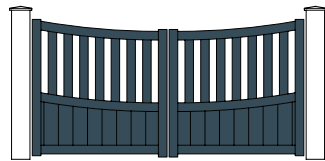

BA 325



BA 326

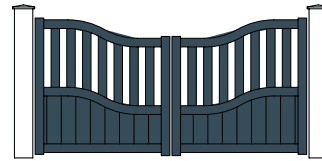

BA 327



BA 326 - Option : traverse intermédiaire à 70%

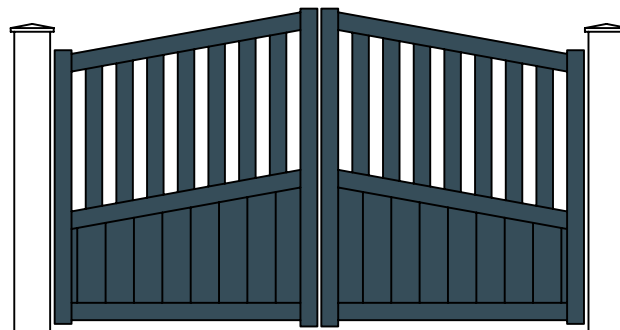

BA 322

## PLANE

BA + CS + CB

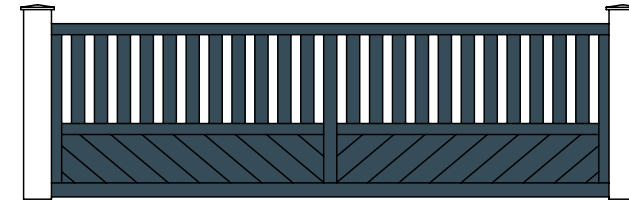

CS 341

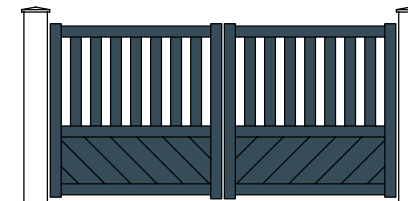

BA 341 / CB 341



BA 342 / CB 342



BA 343 / CB 343

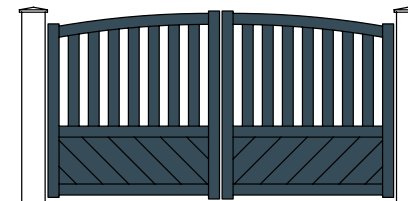

BA 344 / CB 344

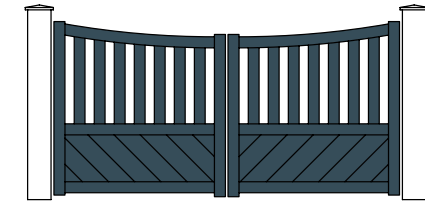

BA 345 / CB 345

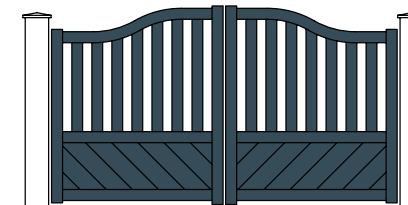

BA 346 / CB 346

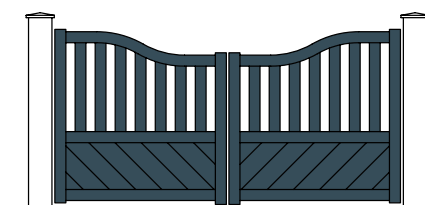

BA 347 / CB 347

Portail BA 311 grande longueur



Portail BA 314 et clôture CL 101









BA : Battant



CS : Coulissant



CB : Coulissant aspect Battant

DESIGNER



# JONQUES

BA + CB



STANDARD

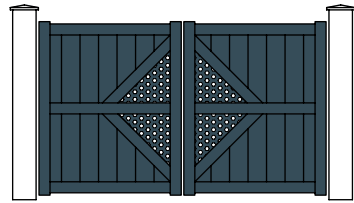

BA 251 / CB 251

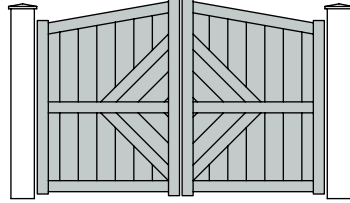

BA 252 / CB 252

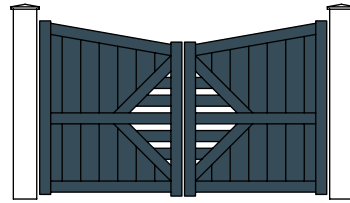

BA 253 / CB 253

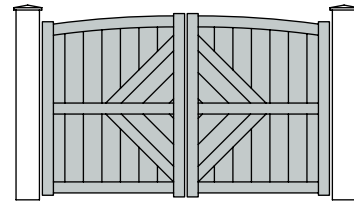

BA 254 / CB 254

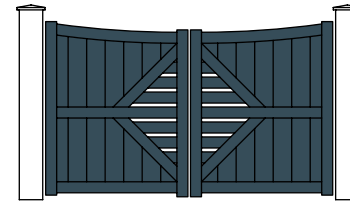

BA 255 / CB 255

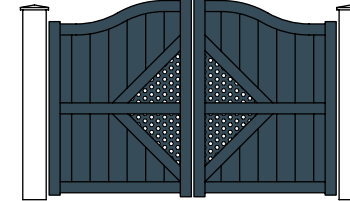

BA 256 / CB 256

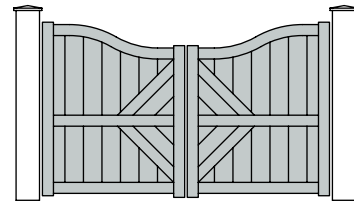

BA 257 / CB 257



BA 252 avec option de remplissage barreaux

### Options de remplissage



Lames doubles



Tolés perforés



Barreaux

# GALION

BA + CS



TOLE

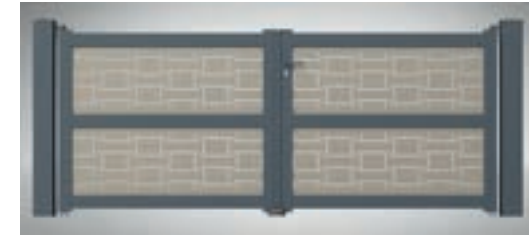

BA 261

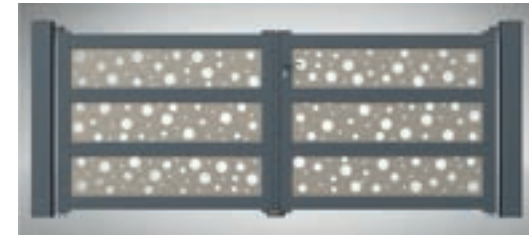

BA 262



CS 261



CS 262



**BA : Battant**

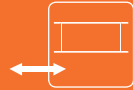

**CS : Coulissant**

**DESIGNER** 

## MIMIZAN + clôture

RAL 7016, 9010, 7039, N 2100 & Noir Bazalt

**NOUVEAU**

BA + CS

Remplissage barreau 25 x 25 mm, remplissage barreau de 50 x 25 mm, remplissage barreau de 92 x 25 mm.

Vertical :

**BA 271 / CS 271**



BA 271

Remplissage barreau 25 x 25 mm, remplissage barreau de 50 x 25 mm, remplissage barreau de 92 x 25 mm.

Horizontal :

**BA 272 / CS 272**



BA 272



CS 271



CS 272



BA : Battant



CS : Coulissant

DESIGNER



## ROCHEFORT

RAL 7016 & 9010

NOUVEAU

BA + CS

Remplissage lames lisses 163 x 25 mm avec liseret impression visual de lame de 81 mm.

**BA 281 / CS 281 - Vertical**



BA 281

**BA 282 / CS 282 - Horizontal**



BA 282

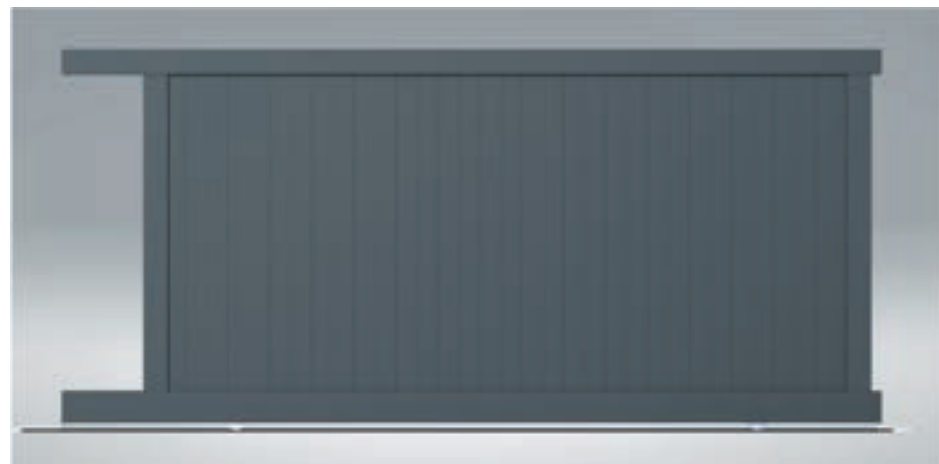

CS 281

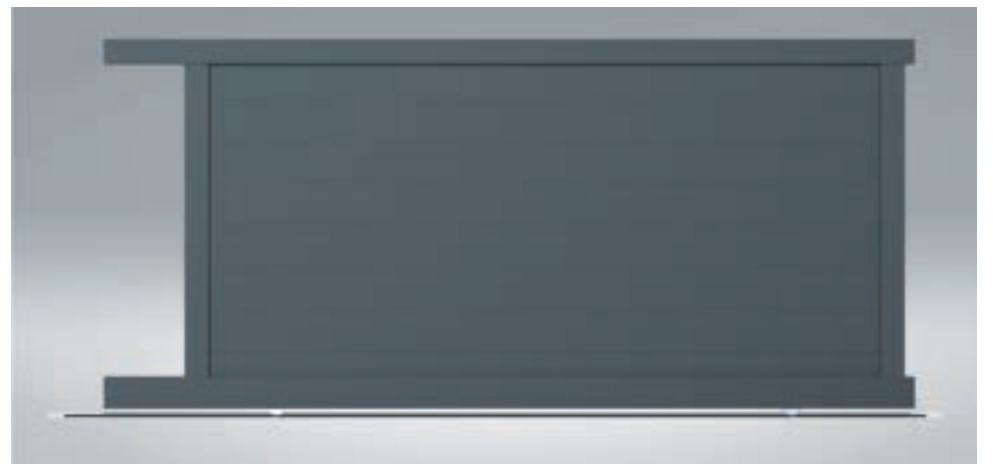

CS 282



BA : Battant



CS : Coulissant

DESIGNER



# TUBA + clôture

RAL 7016, 9010, 7039, N 2100 & Noir Bazalt

**NOUVEAU**

BA + CS

Tube vertical 25 x 25

**BA 291 / CS 291**

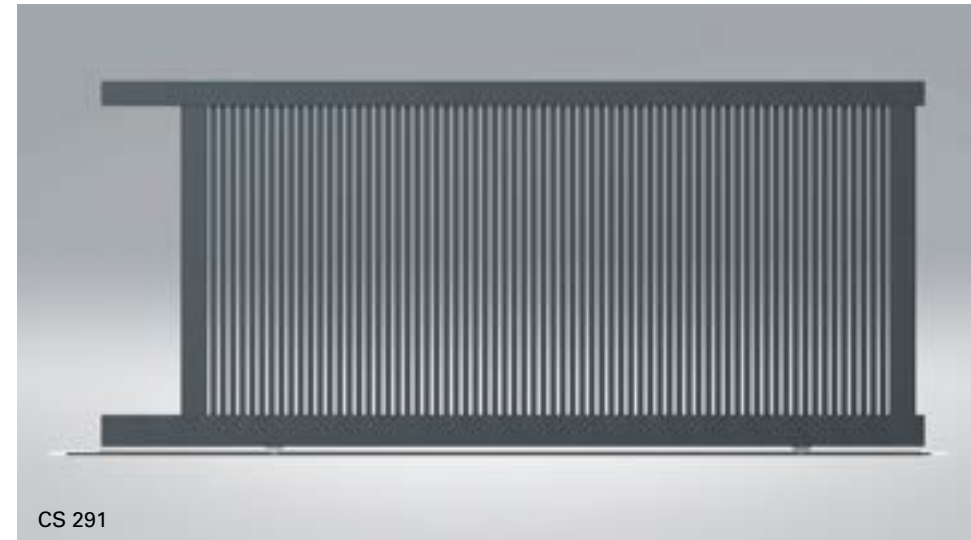



BA : Battant



CS : Coulissant

DESIGNER



## TUBA + clôture p. 172

RAL 7016, 9010, 7039, N 2100 & Noir Bazalt

NOUVEAU

BA + CS

Tube horizontal 25 x 25

**BA 292 / CS 292**

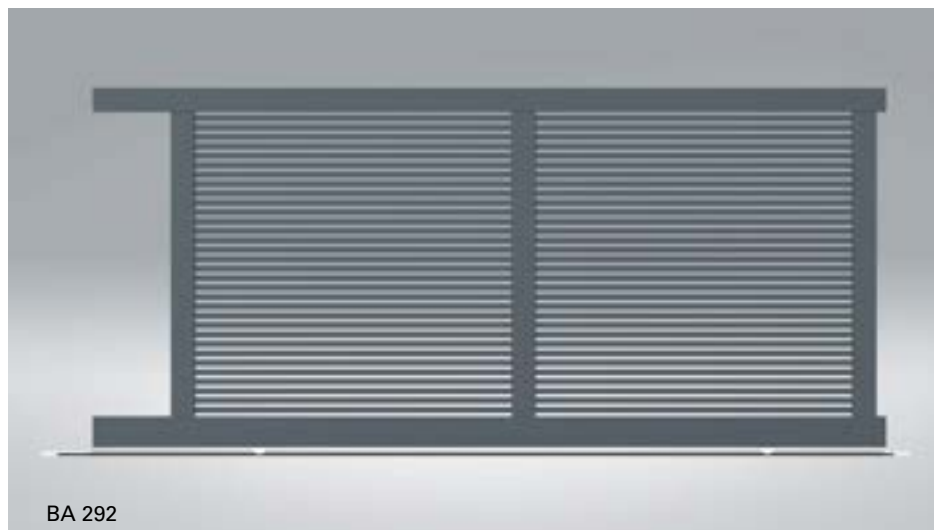

BA 292



Portillon 292

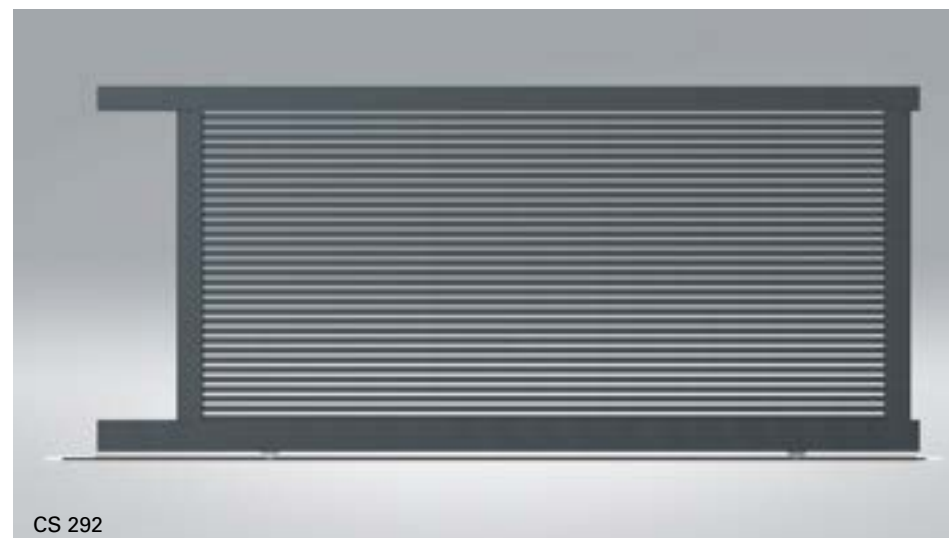

CS 292



BA : Battant



CS : Coulissant



CB : Coulissant aspect Battant

DESIGNER



STANDARD

OPTION

## CARAVELLE

BA + CS

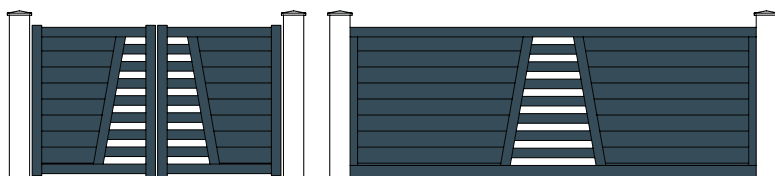

BA 354

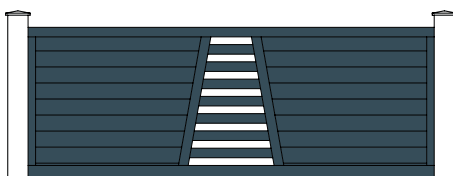

CS 354

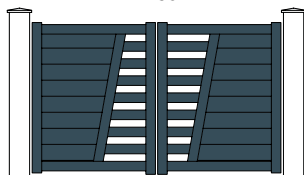

BA 355

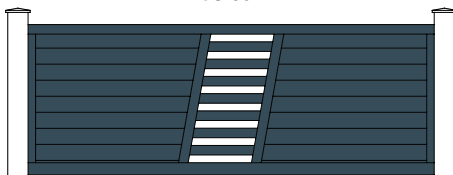

CS 355

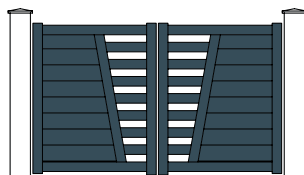

BA 356

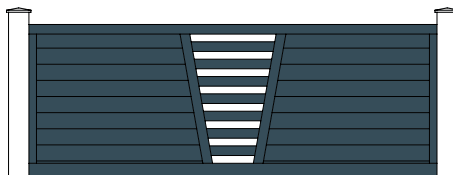

CS 356



Ensemble personnalisé en coloris chêne antique

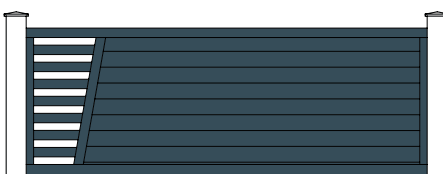

CS 357

## FERRY

BA + CB + CS



STANDARD

OPTION

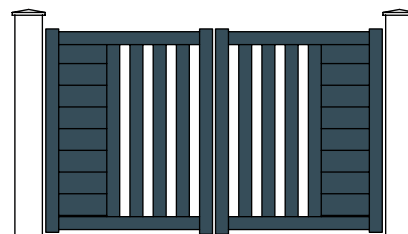

BA 362 / CB 362

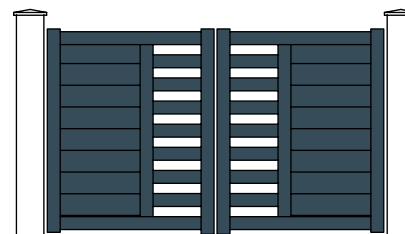

BA 364 / CB 364

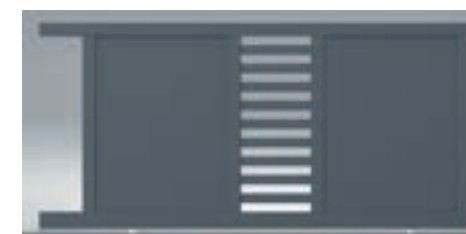

CS 364



BA : Battant



CS : Coulissant



CB : Coulissant aspect Battant

DESIGNER



## PIROGUE

BA + CS

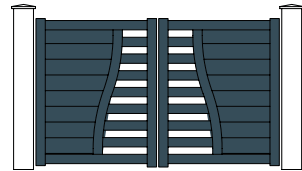
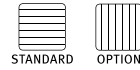

BA 376

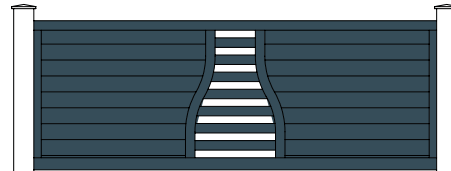

CS 376

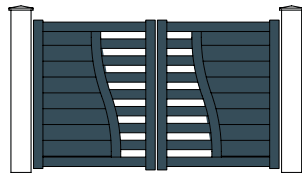

BA 377

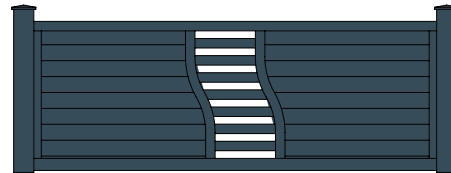

CS 377

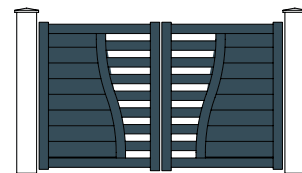

BA 386

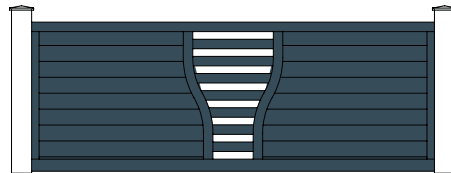

CS 386

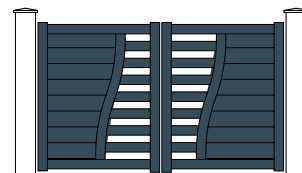

BA 387

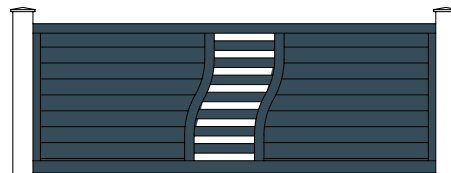

CS 387

## PAQUEBOT

BA + CS

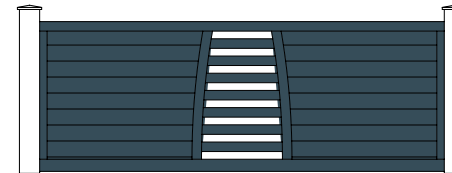
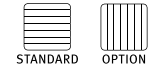

CS 374

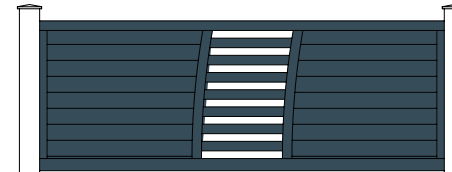

CS 375

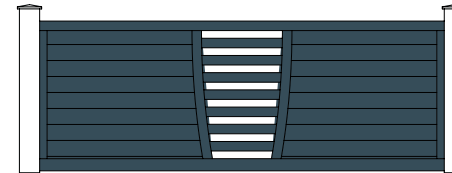

CS 384

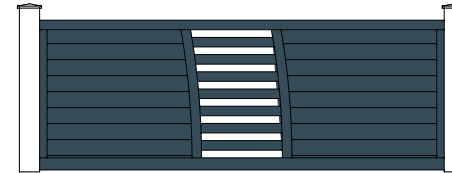

CS 385

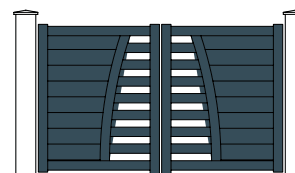
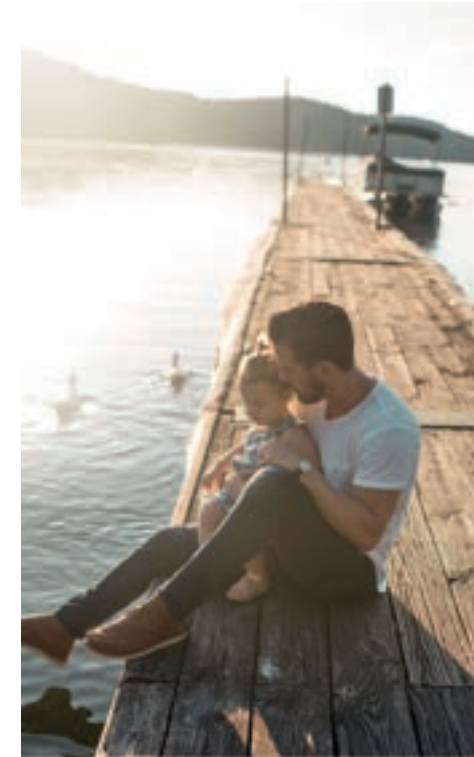

BA 374

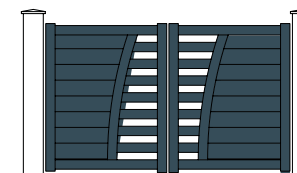

BA 375

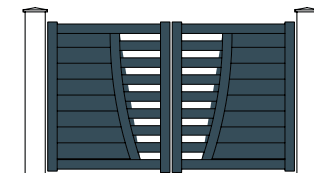

BA 384

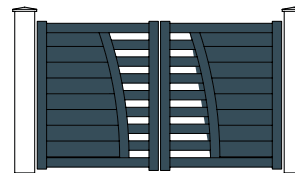

BA 385







BA : Battant



CS : Coulissant



CB : Coulissant aspect Battant

DESIGNER



## FRÉGATE

BA + CS

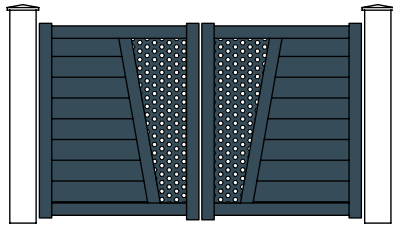
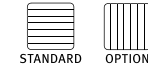

BA 391

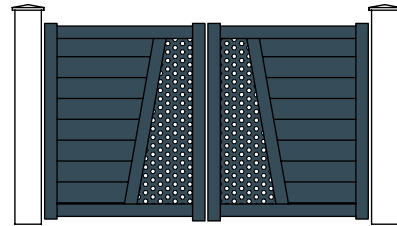

BA 392

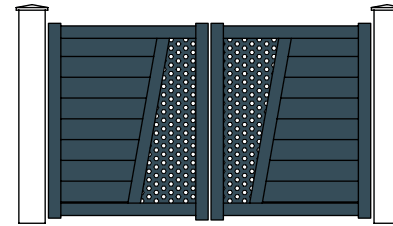

BA 393

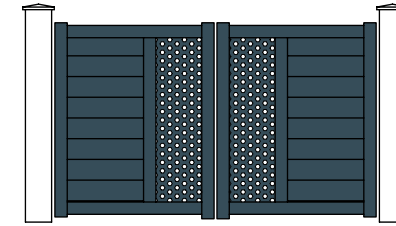

BA 396

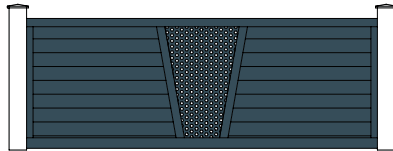

CS 391

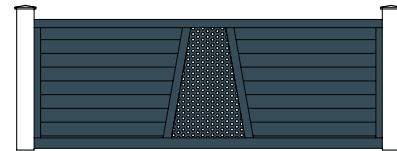

CS 392

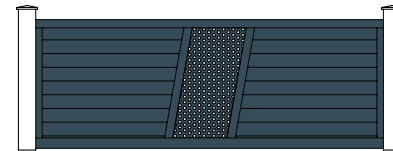

CS 393

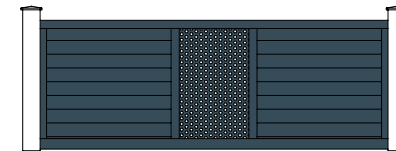

CS 396



Portillon BA 396

## TÔLES PERFORÉES

choix des motifs



1  
Trous  
ø 5 mm



2  
Trous  
ø 10 mm



3  
Rectangles  
5x15 mm

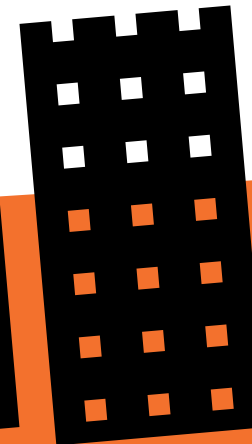

4  
Carrés  
10x10 mm

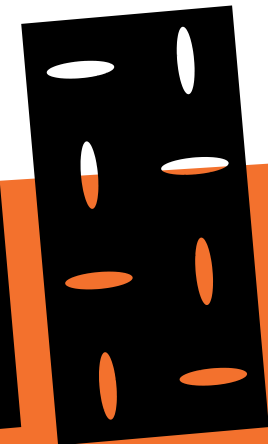

5  
Oblong  
32x8 mm



BA : Battant



CS : Coulissant

DESIGNER



## BEAUNE

RAL 7016, 9010, 7039, N 2100 & Noir Bazalt

NOUVEAU

BA + CS

Lame trapèze **160 in/out bas à 40% ou 50%** environ et lame trapèze 128 haut

**BA 401 / CS 401**



BA 401

Lame trapèze **160 in/out bas à 40% ou 50%** environ et lame trapèze 128 haut  
espacé de 25 mm

**BA 402 / CS 402**



BA 402



CS 401



CS 402



BA : Battant



CS : Coulissant

DESIGNER



## IRANCY

RAL 7016, 9010, 7039, N 2100 & Noir Bazalt

NOUVEAU

BA + CS

Lame trapèze **160 in/out bas à 60%** environ et lame trapèze 128 haut

**BA 403 / CS 403**



BA 403

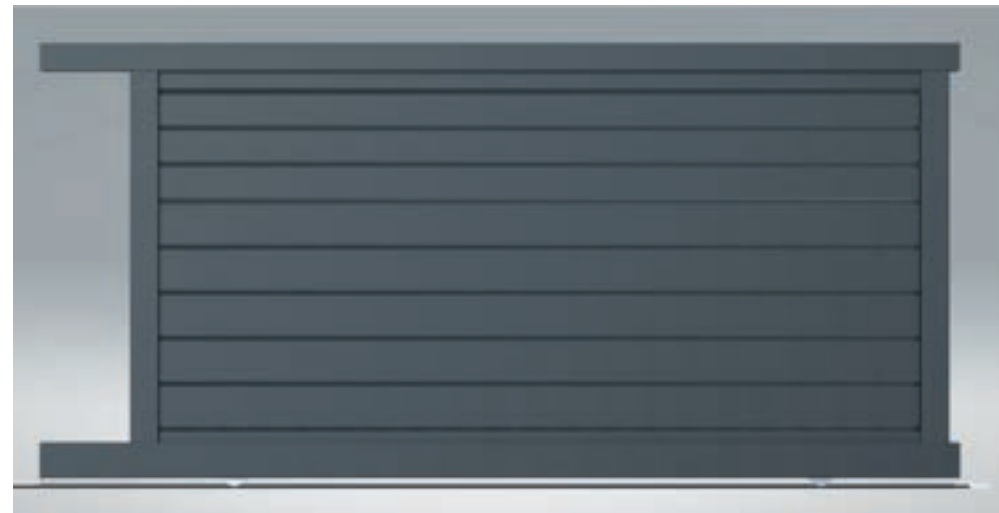

CS 403

Lame trapèze **160 in/out bas à 60%** environ et lame trapèze 128 haut  
espacé de 25 mm

**BA 404 / CS 404**



BA 404



CS 404



**BA : Battant**



**CS : Coulissant**

**DESIGNER**

## LANGRES + clôture

**NOUVEAU**

BA + CS

Lame trapèze 128 x 25 mm.

**BA 405 / CS 405**

RAL 7016, 9010, 7039, N 2100 & Noir Bazalt



BA 405



Zoom  
CS 405

CS 405

## ADOUR + clôture

**NOUVEAU**

BA + CS

Lame trapèze 128 x 25 mm + tôle décorative (au choix matrice ou brindille)

**BA 406 / CS 406**

RAL 7016, 9010, 7039, N 2100 & Noir Bazalt



BA 406



CS 406





BA : Battant



CS : Coulissant

DESIGNER



# JABLOIR

BA + CS

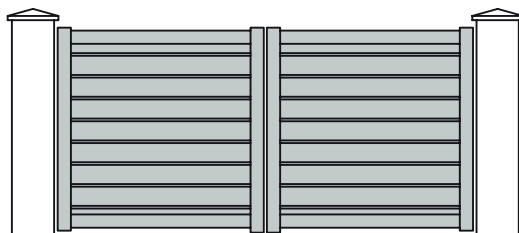

BA 408

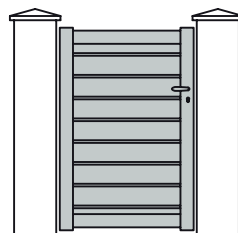

BA 408

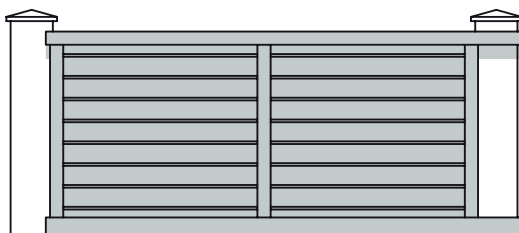

CS 408

NOUVEAU

Réalisable en autoportant (p.164)



Portail CS 408 avec montant central

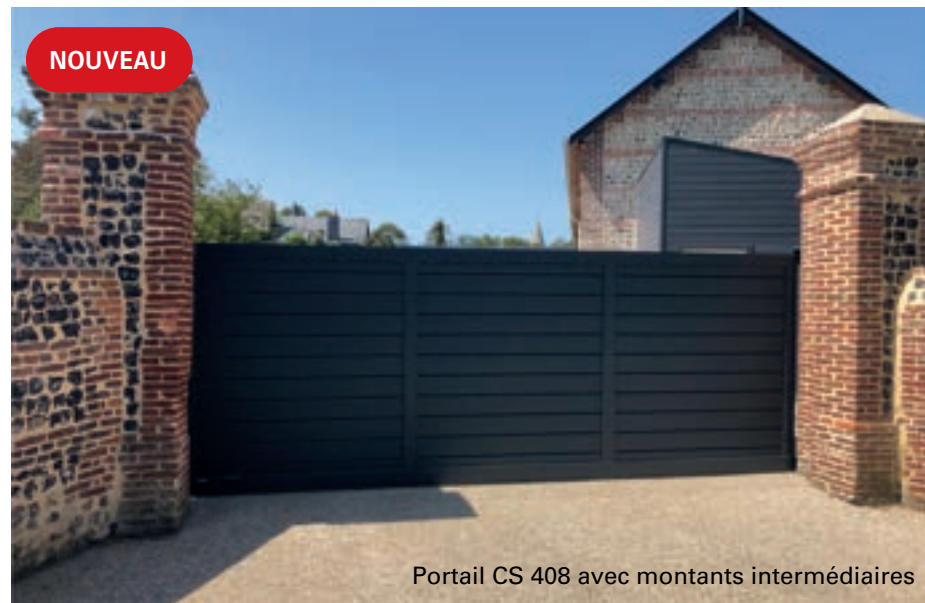

NOUVEAU

Portail CS 408 avec montants intermédiaires

Extérieur | Intérieur

De l'intérieur vers l'extérieur :  
vue sur la rue

De l'extérieur vers l'intérieur :  
vue sur le ciel

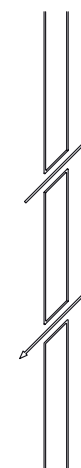



BA : Battant



CS : Coulissant

DESIGNER



## JABLOIR

BA + CS



BA 428



CS 428



BA 508



CS 508



Portillon 428



Portillon 508

## JABLOIR DÉCOR

NOUVEAU

BA + CS

Lames 160 x 25 mm + tôle décorative épaisseur 2mm.

BA / CS 418

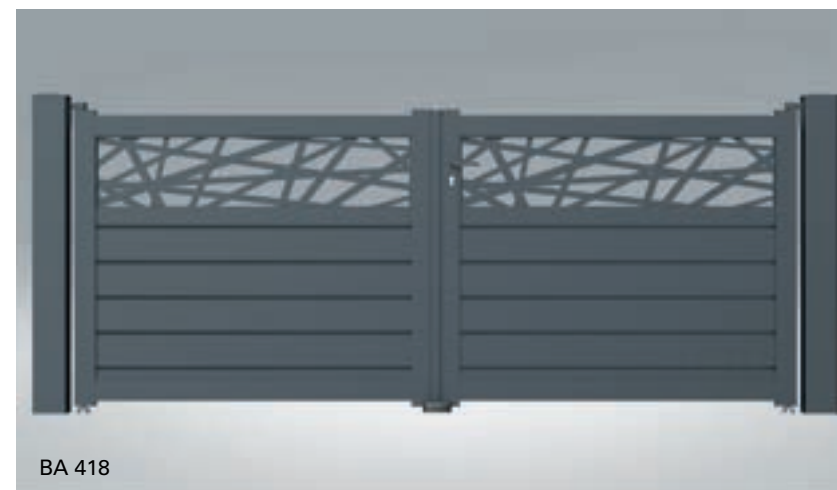

BA 418



CS 418



BA : Battant



CS : Coulissant

DESIGNER



## TOULON

RAL 7016, 9010, 7039, N 2100 & Noir Bazalt

NOUVEAU

BA + CS

Remplissage barreaux lisses de 25 x 25 partie haute. Remplissage lames lisses de 163 x 25 mm soubassement de 40%, 50% ou 60% environ.

**BA 432 / CS 432**



BA 432



CS 432

Remplissage barreaux lisses de 50 x 25 partie haute. Remplissage lames lisses de 163 x 25 mm soubassement de 40%, 50% ou 60% environ.

**BA 433 / CS 433**

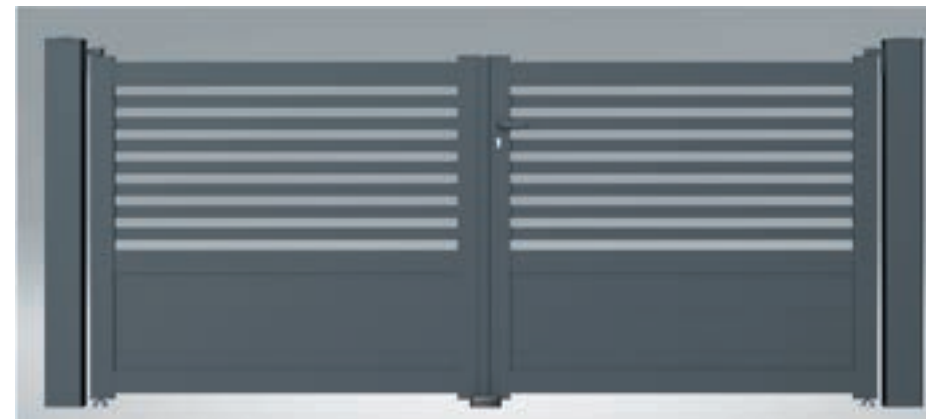

BA 433

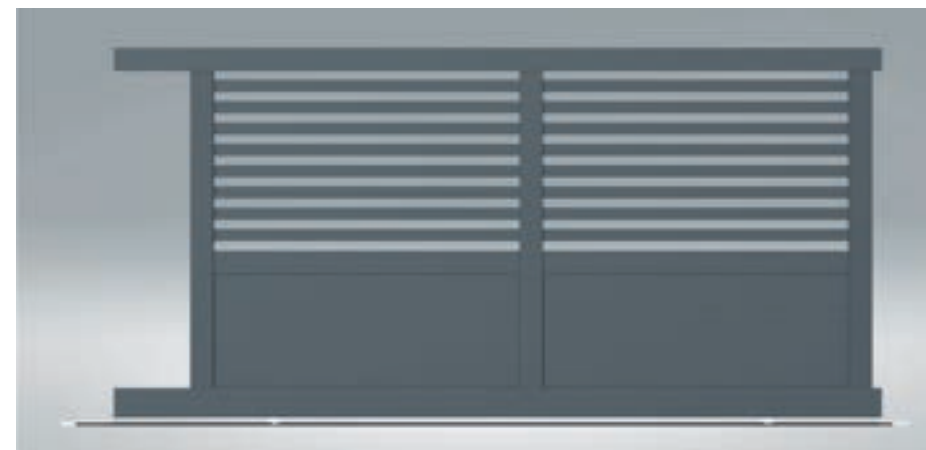

CS 433





BA : Battant



CS : Coulissant

DESIGNER



## TOULON

RAL 7016, 9010, 7039, N 2100 & Noir Bazalt

NOUVEAU

BA + CS

Remplissage barreaux lisses de 92 x 25 mm partie haute. Remplissage lames lisses de 163 x 25 mm soubassement de 40%, 50% ou 60% environ.

BA 434 / CS 434



BA 434

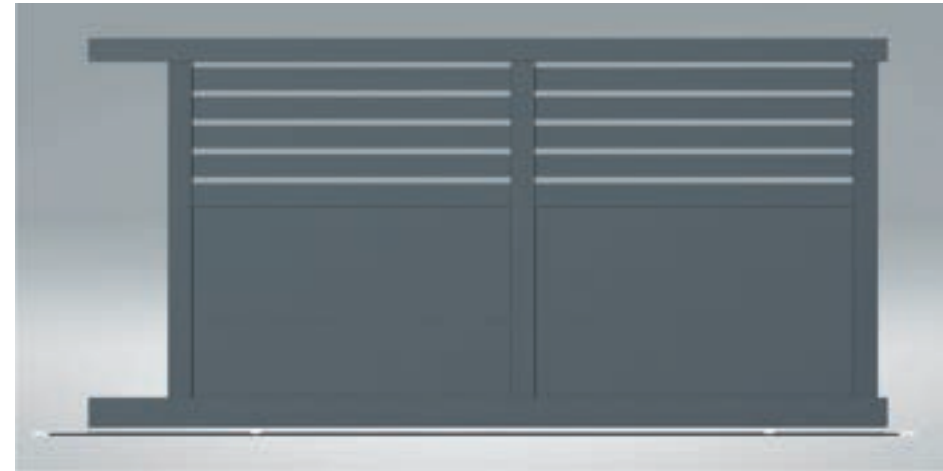

CS 434





BA : Battant



CS : Coulissant

DESIGNER



## TARBES

RAL 7016, 9010, 7039, N 2100 & Noir Bazalt

NOUVEAU

BA + CS

Remplissage lames trapèze de 128 x 25 mm partie haute. Remplissage lames lisses de 163 x 25 mm soubassement 40%, 50% ou 60% environ, avec recouvrement de 5 mm.

**BA 435 / CS 435**



BA 435



CS 435

Remplissage lames trapèze de 128 x 25 mm partie haute. Remplissage lames lisses de 163 x 25 mm soubassement 40%, 50% ou 60% environ, avec espacement de 25 mm.

**BA 436 / CS 436**



BA 436



CS 436



BA : Battant



CS : Coulissant

DESIGNER



## CHARENTE

NOUVEAU

BA + CS

Remplissage barreaux lisses de 92 x 25 mm partie haute. Remplissage lames lisses de 163 x 25 mm soubassement de 70% environ.

**BA 437 / CS 437**



BA 437



CS 437





BA : Battant



CS : Coulissant

# NOUMÉA

Choix des tôles en p. 120 et p. 121

P.110 à 115 : le choix de la couleur de la tôle est à définir et non par défaut

BA + CS

**Tôle découpe laser au choix :** "Sphérique", "Matrice", "Brique", "Volante", "Brindille", "Florale", "Tribale", "Alvéole", "Poinçon", "Flèche", "Carrel", "Moucharabieh" ou "Mosaïque"

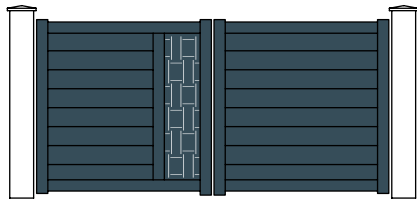

BA 708  
avec "Brique"

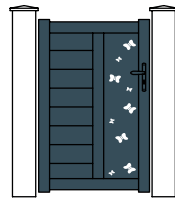

BA 708  
avec "Volante"



BA 708  
avec "Florale"



CS 708  
avec "Florale"

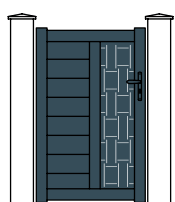

BA 708  
avec "Brique"



BA 708  
avec "brindille"

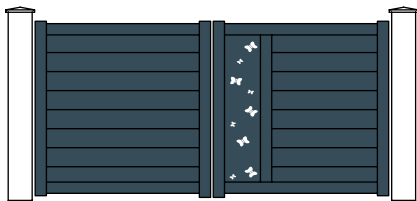

BA 718  
avec "Volante"

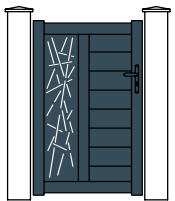

BA 718  
avec "Brindille"



BA 718  
avec "Brique"

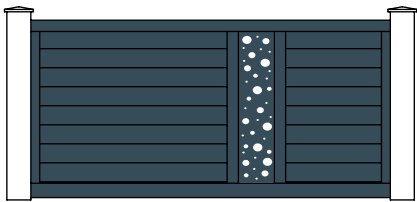

CS 718  
avec "Sphérique"

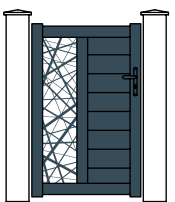

BA 718  
avec "Matrice"



BA 718  
avec "Sphérique"



Portail BA 708 avec tôle brique



Portail CS 718 avec tôle sphérique



BA : Battant



CS : Coulissant

YACHTING 



Portail CS 708 avec tôle brindille



Portail BA 718 avec tôle matrice



Portail CS 708 avec tôle brique



Portail BA 718 avec tôle volante



Portail BA 718 avec tôle florale



BA : Battant



CS : Coulissant

YACHTING



# MARIGOT Choix des tôles en p. 120 et p. 121

BA + CS

**Tôle découpe laser au choix :** "Sphérique", "Matrice", "Brique", "Volante", "Brindille", "Florale", "Tribale", "Alvéole", "Poinçon", "Flèche", "Carrel", "Moucharabieh" ou "Mosaïque"

\* Renfort dans la traverse basse

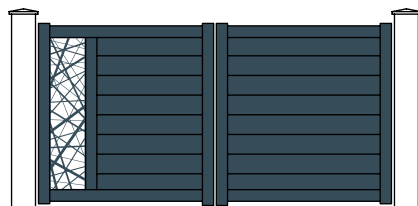

BA 728 \*  
avec "Matrice"

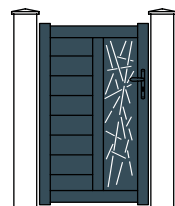

BA 708  
avec "Brindille"

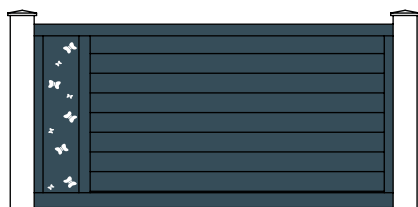

CS 728  
avec "Volante"

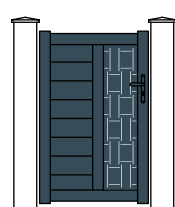

BA 708  
avec "Brique"

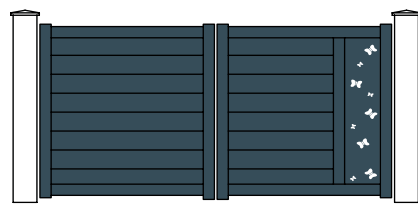

BA 738 \*  
avec "Volante"

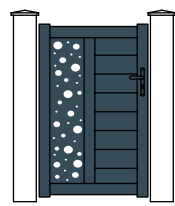

BA 718  
avec "Sphérique"

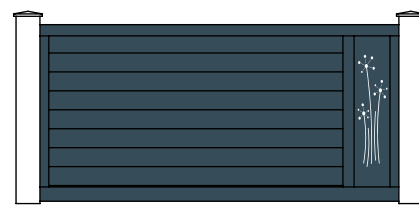

CS 738  
avec "Florale"

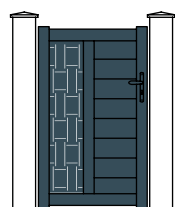

BA 718  
avec "Brique"



Portail BA 728 avec tôle matrice



Portail CS 738 avec tôle florale



BA : Battant



CS : Couissant

YACHTING



## PAPEETE

Choix des tôles en p. 120 et p. 121

BA + CS

**Tôle découpe laser au choix :** "Sphérique", "Matrice", "Brique", "Volante", "Brindille", "Florale", "Tribale", "Alvéole", "Poinçon", "Flèche", "Carrel", "Moucharabieh" ou "Mosaïque"

\* Renfort dans la traverse basse



BA 748  
avec "Sphérique"

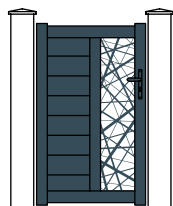

BA 708  
avec "Matrice"

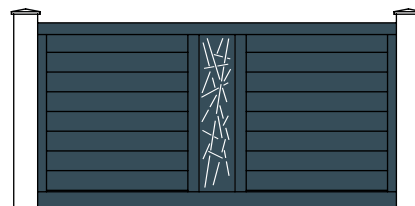

CS 748  
avec "Brindille"

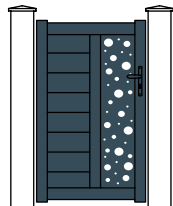

BA 708  
avec "Sphérique"

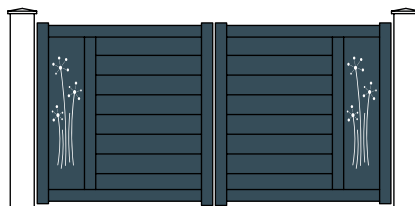

BA 758 \*  
avec "Florale"

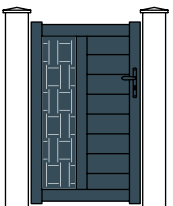

BA 718  
avec "Brique"

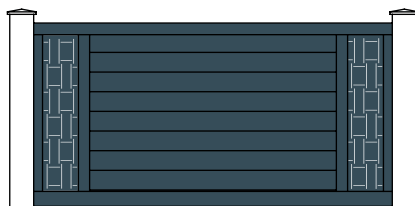

CS 758  
avec "Brique"

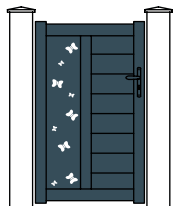

BA 718  
avec "Volante"



Portail CS 748 avec tôle brindille



Portail BA 748 avec tôle sphérique



BA : Battant



CS : Coulissant

YACHTING



# CAYENNE

Choix des tôles en p. 120 et p. 121

BA + CS

**Tôle découpe laser au choix :** "Sphérique", "Matrice", "Brique", "Volante", "Brindille", "Florale", "Tribale", "Alvéole", "Poinçon", "Flèche", "Carrel", "Moucharabieh" ou "Mosaïque"

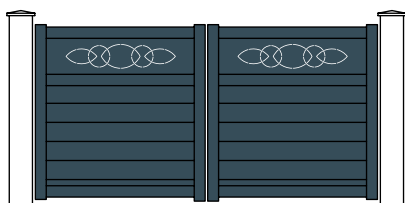

BA 768  
avec "Tribale"



BA 768  
avec "Volante"



BA 768 avec "Volante"

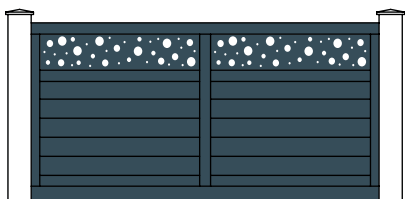

CS 768  
avec "Sphérique"

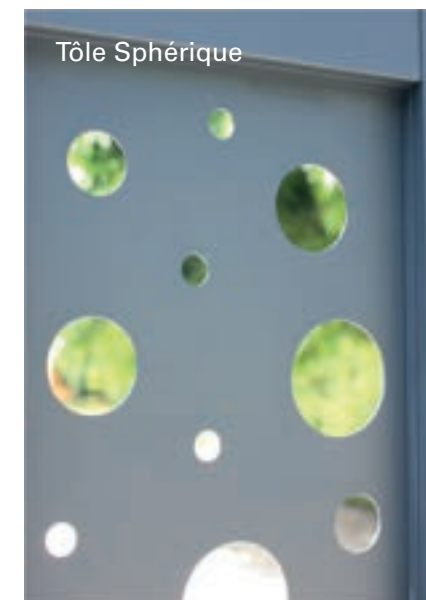

Tôle Sphérique

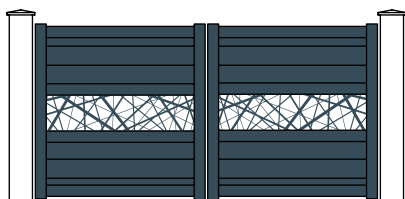

BA 778  
avec "Matrice"

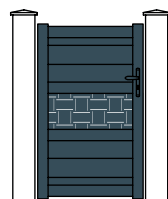

BA 778  
avec "Brique"



BA 778 avec "Brique"



Tôle Matrice

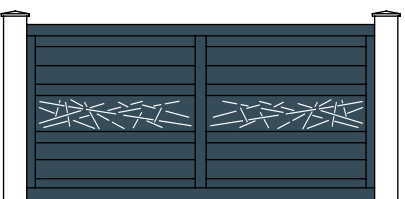

CS 778  
avec "Brindille"





BA : Battant



CS : Coulissant

YACHTING



Portail BA 768 avec tôle tribale



Portail BA 778 avec tôle brindille



Portail CS 768 avec tôle sphérique



Portail CS 778 avec tôle brindille



BA : Battant



CS : Coulissant

YACHTING



## COLLECTION WOOD

WOOD SEUL



WOOD VAGUE





BA : Battant



CS : Coulissant

YACHTING



## COLLECTION WOOD

WOOD NOIR INFINI - RAINURES

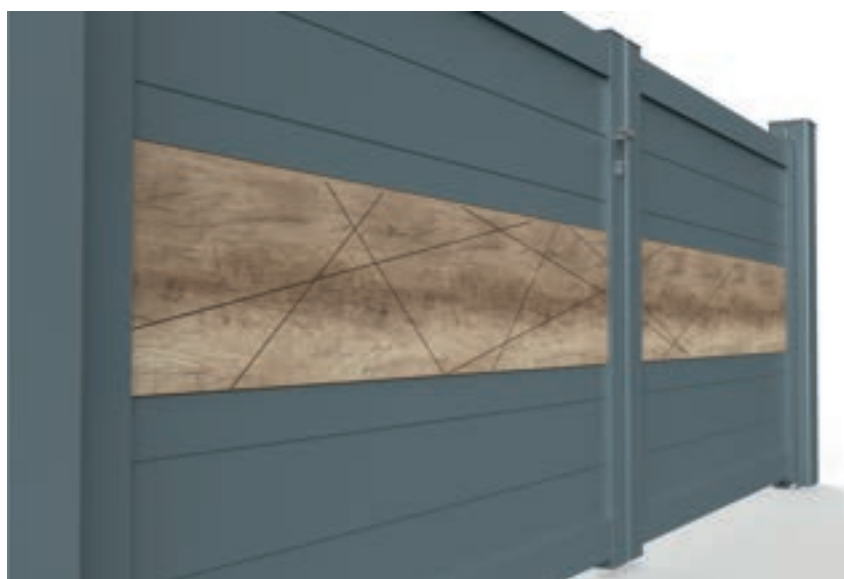

WOOD NOIR INFINI - LOSANGES



## TÔLES PERFORÉES

largeur 300 ou 450 mm | choix des motifs

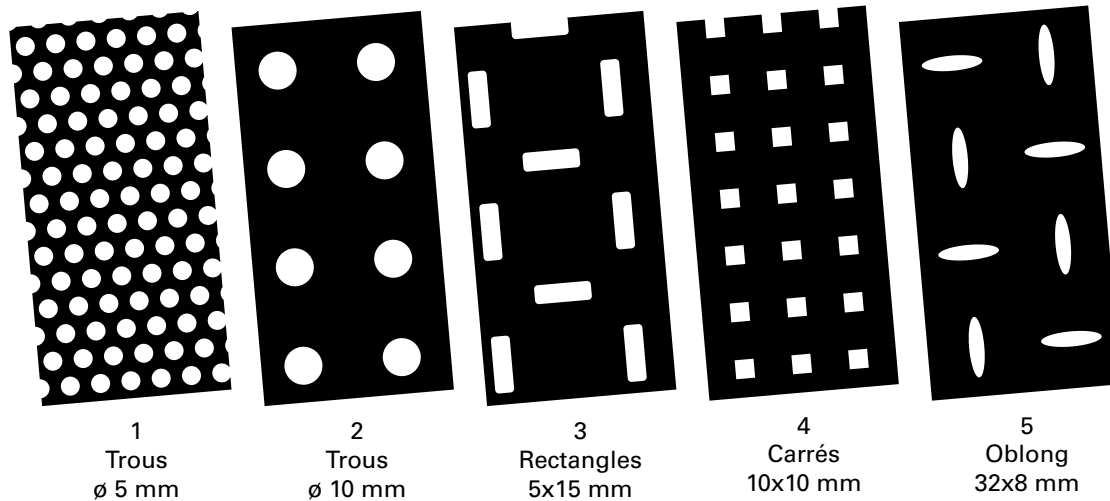

Zoom sur tôle perforée trou n°5



## TÔLES IN LOVE



In love 1



In love 2



In love 3

## TÔLES DÉCOUPE LASER

largeur 310 ou 450 mm | choix des motifs  
autres découpes sur consultation

**NOUVEAU**

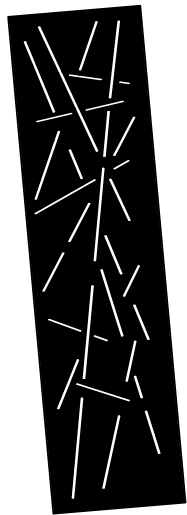

Brindille

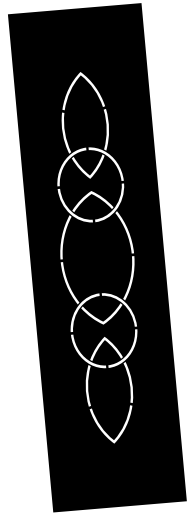

Tribale

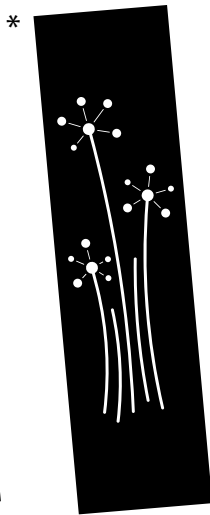

Florale \*

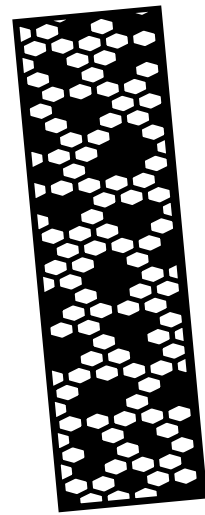

Alvéole

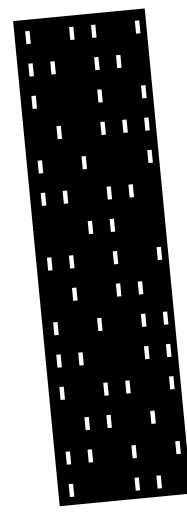

Poinçon



Flèche



Carrel

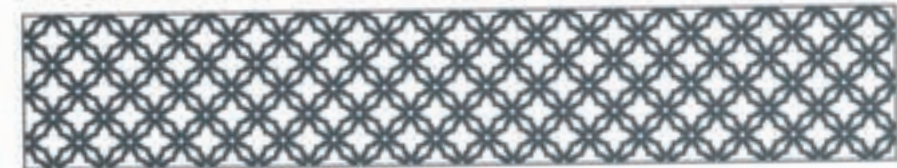

Moucharabieh

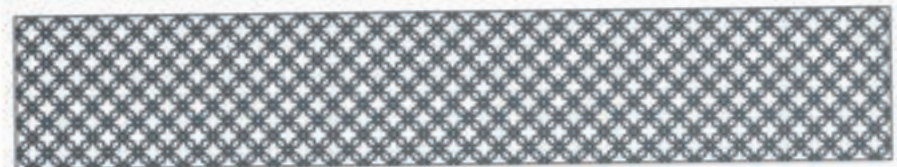

Mosaïque

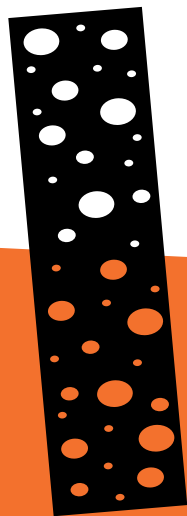

Sphérique

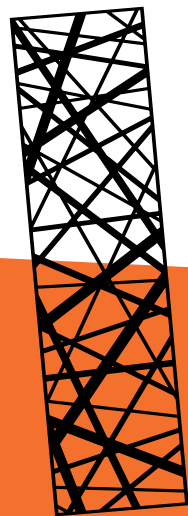

Matrice

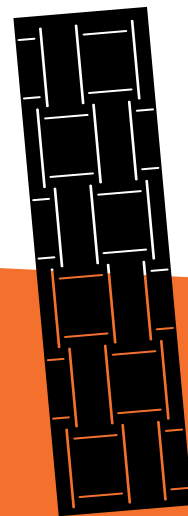

Brique

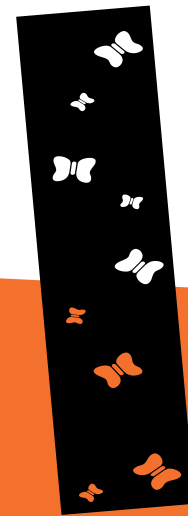

Volante

\* Uniquement en position verticale et largeur 450 mm



Zoom «Vagues» hauteur 75 mm Aluinox



BA : Battant



CS : Coulissant



CB : Coulissant aspect Battant

YACHTING



## HERMIONE

BA + CS

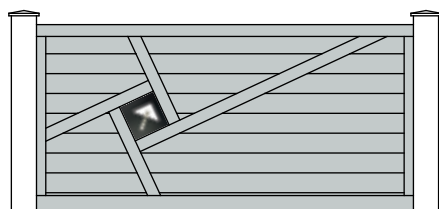

CS 808

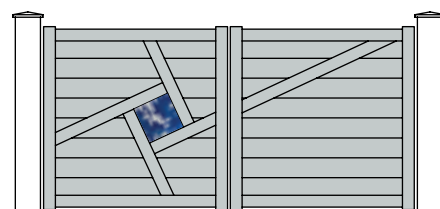

BA 808

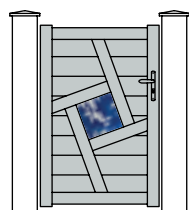

BA 808

Fusings



Panaché bleu



Panaché vert



Panaché orangé

OU

Tôles découpées + inserts alu-inox pour C & D

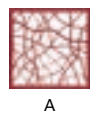

A

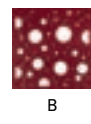

B



C



D

## GABARES

BA + CB

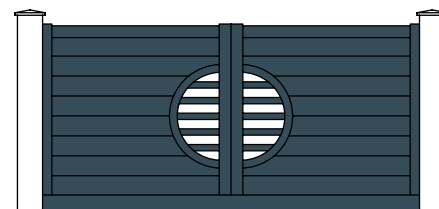

CB 818  
Rond barreaudé

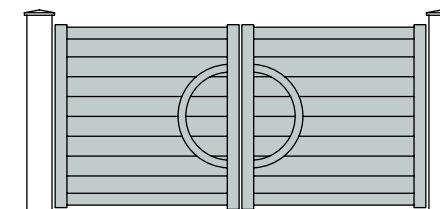

BA 818  
Rond plein

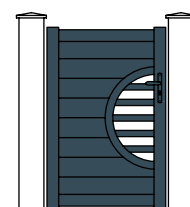

BA 818

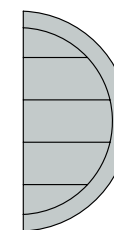

Rond plein  
lames de  
163 mm



Rond  
barreaudé  
barreaux  
50 mm



BA 808 / CB 808

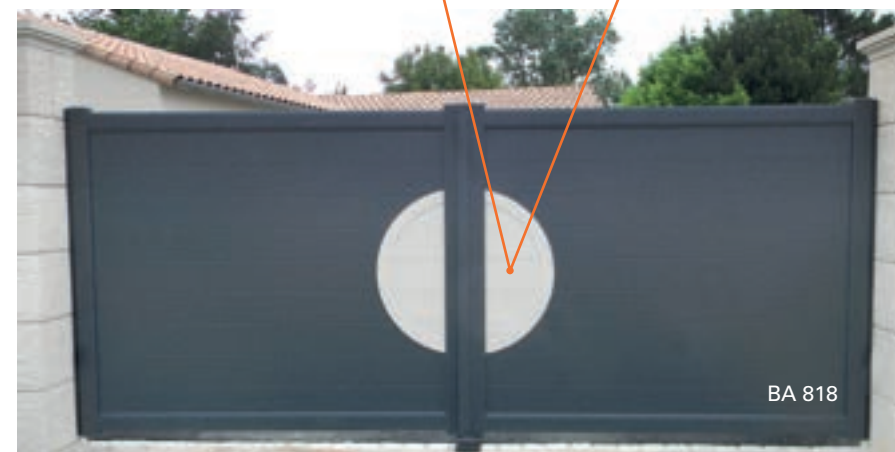

BA 818



BA : Battant



CS : Coulissant

YACHTING



## CLIPPER

BA + CS

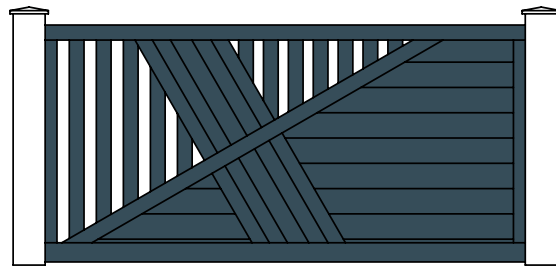

CS 828

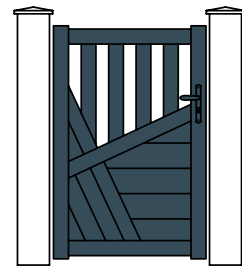

BA 828



Portail CS 828

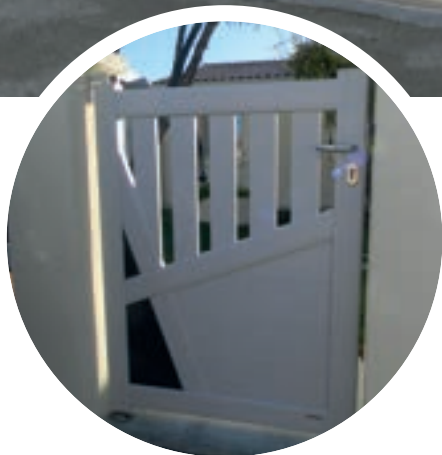

## SABORD

BA + CS

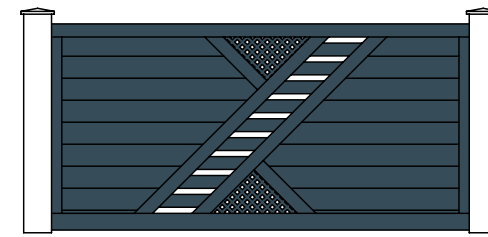

CS 838

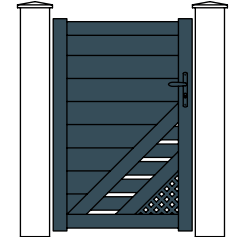

BA 838

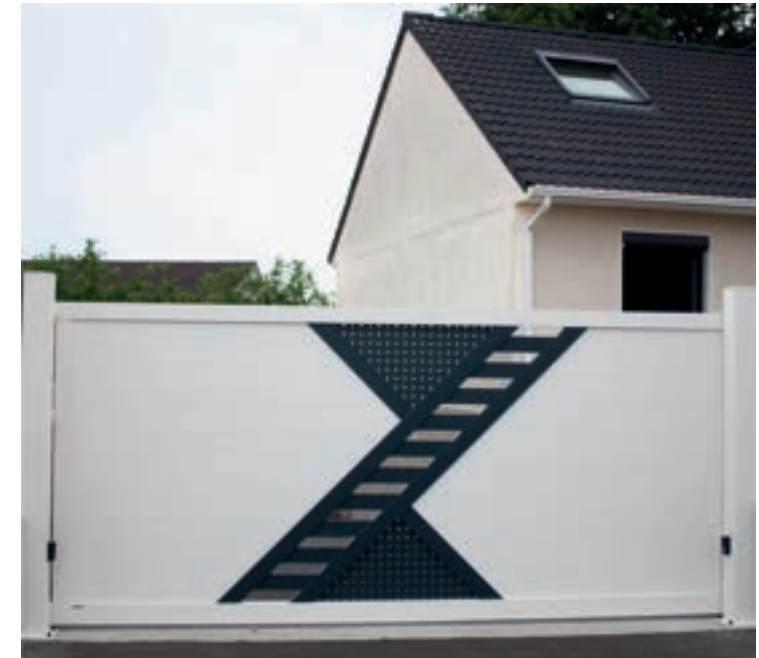

Portail CS 838





**BA** : Battant



**CS** : Coulissant

YACHTING



## ARGELES

RAL 7016, 9010, 7039, N 2100 & Noir Bazalt

**NOUVEAU**

BA + CS

Remplissage lames liseret de 16 x 25 mm, remplissage lames lisses de 163 x 25 mm, remplissage lames lisses de 300 x 25 mm.

Vertical

**BA 846 / CS 846**



BA 846 - Vertical

Horizontal

**BA 847 / CS 847**



BA 847 - Horizontal



CS 846 - Vertical

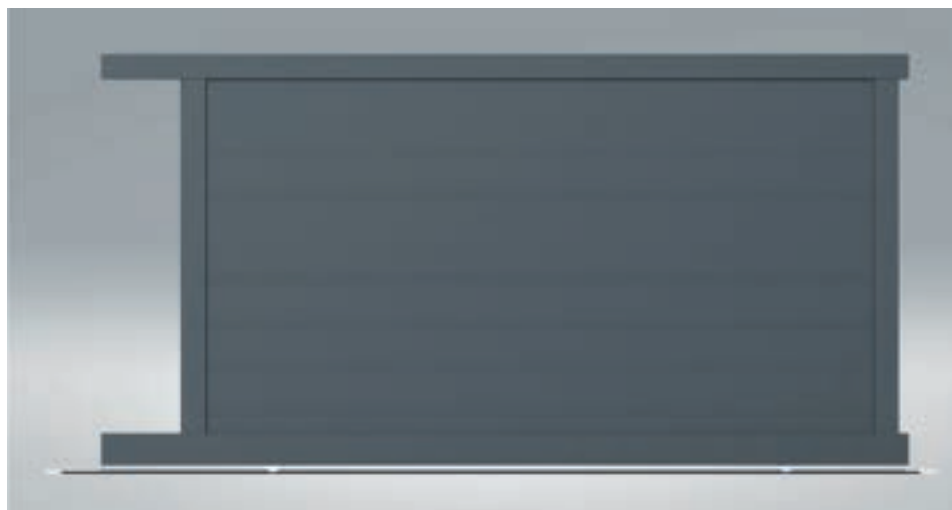

CS 847 - Horizontal



BA : Battant



CS : Coulissant

YACHTING



## MATELOT

BA + CS

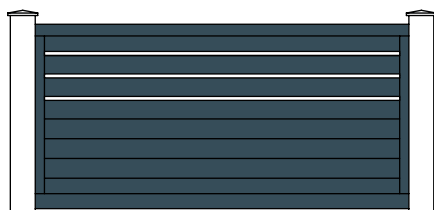

CS 848

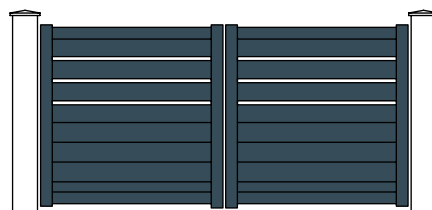

BA 848

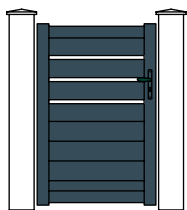

BA 848

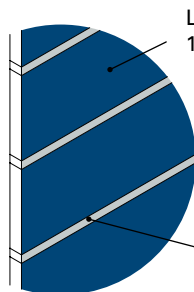

Lames de 163 mm

Liserets de 21 mm Alu brossé ou Club Color

Portail BA 848



## CORVETTE

CS

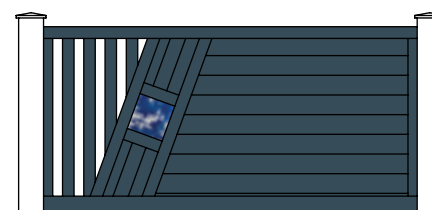

CS 858

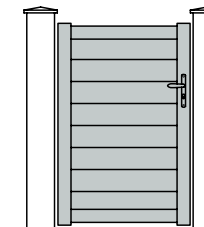

BA 208

Fusings :



Panaché bleu



Panaché vert



Panaché orangé



CS 858



BA : Battant



CS : Coulissant

YACHTING



## BELEM - Hauteur lames 250 mm\*

BA + CS

\* Uniquement 4 coloris (9010 G, 7016 G, 7035 G, N 2100)



Portail CS 868 avec montant central



CS 868

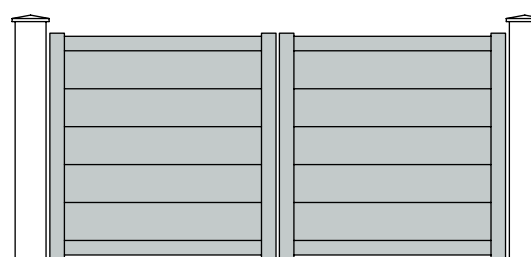

BA 868

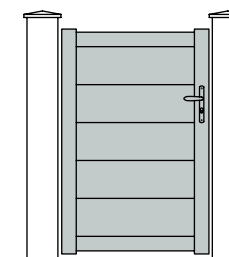

BA 868



BA : Battant



CS : Coulissant

MENUISIER 

## AUPPEGARD

RAL 7016, 9010, 7039, N 2100 & Noir Bazalt

NOUVEAU

BA + CS

Modèle horizontal - Lames 300

**BA 878 / CS 878**



BA 878

Modèle vertical - Lames 300

**BA 879 / CS 879**



BA 879

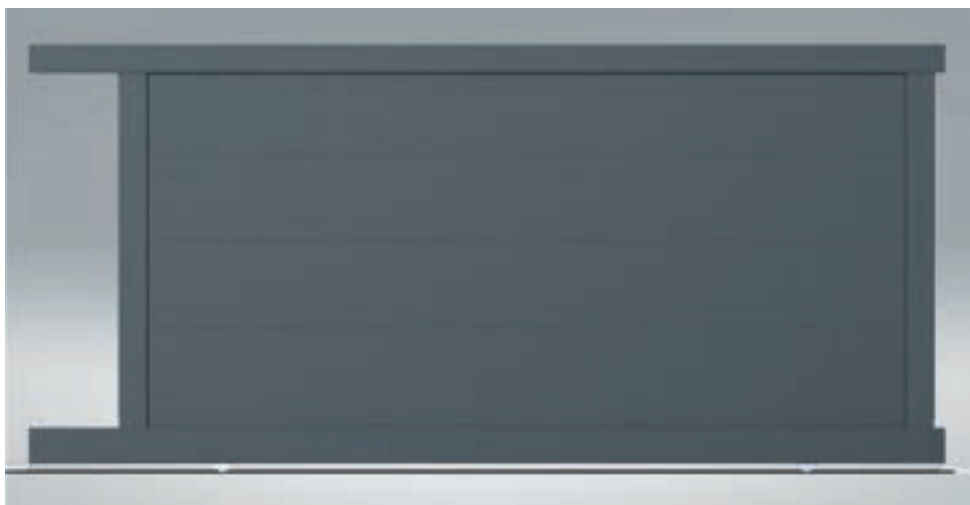

CS 878

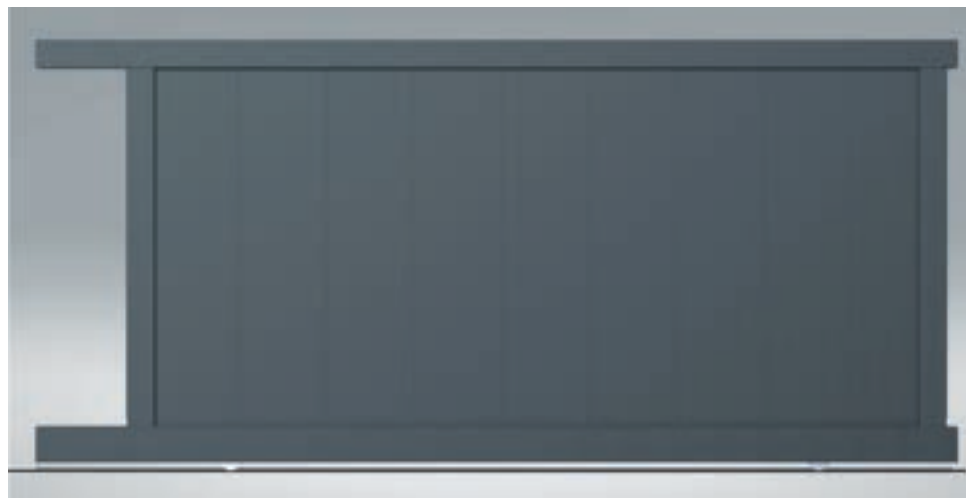

CS 879



BA : Battant



CS : Coulissant

YACHTING



## LA POUPE

NOUVEAU

BA + CS

### Modèle simple ligne

Remplissage lames lisses 163 x 25 mm  
Dégradé de ligne 50 mm Aluinox

BA 907 / CS 907



### Modèle double lignes

Remplissage lames lisses 163 x 25 mm  
Dégradé de ligne 50 mm Aluinox

BA 907 / CS 907



Remplissage lames lisses 163 x 25 mm  
Dégradé de ligne 50 mm Aluinox + Bois



BA 907 - ligne simple Aluinox + bois

Remplissage lames lisses 163 x 25 mm  
Dégradé de ligne 50 mm Aluinox + Bois





BA : Battant



CS : Couissant

YACHTING



## LA POUPE

BA + CS

### Modèle double lignes centrales

BA 907 / CS 907

Remplissage lames lisses 163 x 25 mm  
Dégradé de ligne 50 mm Aluinox



BA 907 - double lignes Aluinox

Remplissage lames lisses 163 x 25 mm  
Dégradé de ligne 50 mm Aluinox + Bois



## MEUSE

BA + CS

### BA 917 / CS 917

Remplissage lames lisses de 163 x 25 mm



BA 917 - Croisé lignes



BA : Battant



CS : Couissant

# GRAND PAVOIS - "Carrés" Remplissage lames lisses 163 x 25 mm

NOUVEAU

BA + CS

- 4 Carrés pleins Aluinox 70 x 70 mm
- 4 Carrés pleins Aluinox 120 x 120 mm
- 4 Carrés ajouré 120 x 120 mm.

**Option :**  
 - 4 Carrés pleins 120 x 120 mm Aluinox + bois ou pierre

**4 Carrés pleins 120 x 120 mm :**

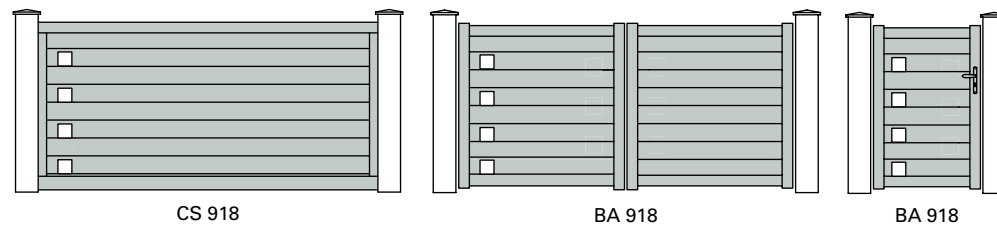
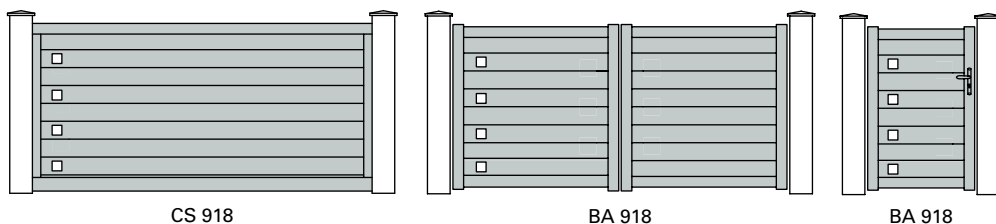

BA 918 - 4 Carrés pleins Aluinox 70 x 70 mm



BA 918 - 4 Carrés pleins Aluinox 120 x 120 mm



BA : Battant



CS : Coulissant



CB : Coulissant aspect Battant

YACHTING



## GRAND PAVOIS - "Carrés"

NOUVEAU

BA + CS

Remplissage lames lisses 163 x 25 mm

BA 918 - 4 Carrés ajourés 120 x 120 mm :



BA 918 - 4 Carrés pleins 120 x 120 mm Aluinox + bois (option) :



## LUNE

NOUVEAU

BA + CS

Remplissage lames lisses 163 x 25 mm

BA 927 / CS 927



BA 927 - lune

Option : modèle Lune avec numéro

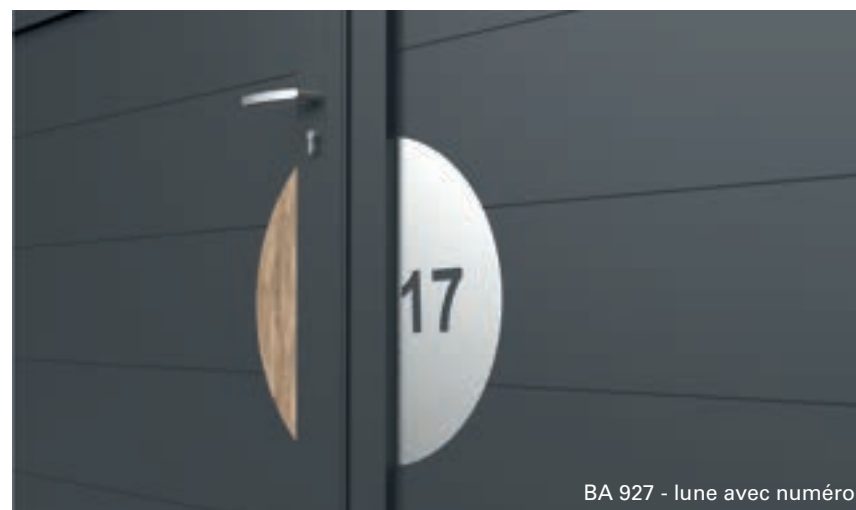

BA 927 - lune avec numéro





BA : Battant



CS : Coulissant

YACHTING



## SABAYE - "S" largeur 75 mm Aluinox

BA + CS

BA / CS 928

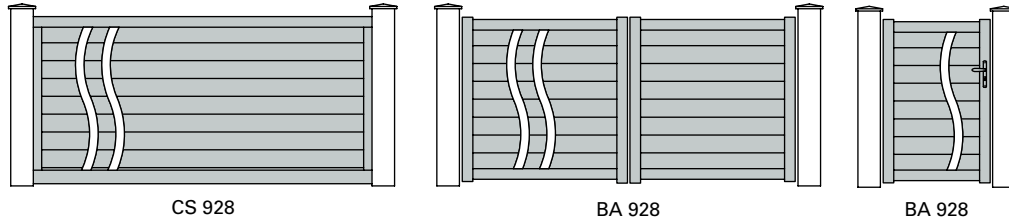

## TRYBAL DÉCO

Remplissage lames lisses 163 x 25 mm

BA + CS

NOUVEAU

TRYBAL DÉCO 31  
BA 937 / CS 937



## TRYBAL DÉCO

Remplissage lames lisses 163 x 25 mm

BA + CS

NOUVEAU

TRYBAL DÉCO 32  
BA 937 / CS 937



TRYBAL DÉCO 33





BA : Battant



CS : Coulissant

YACHTING



## CADENE - Lignes 30'

NOUVEAU

BA + CS

Remplissage lames lisses 163 x 25 mm

BA / CS 938

Cadene simple ligne



BA 938

Option : Cadene double lignes



BA 938

Option : Cadene double lignes centrales



BA 938

## SAONE

NOUVEAU

BA + CS

Remplissage lames lisses 163 x 25 mm

Carré Aluinox avec volcan ou corten / noir infini

BA 947 / CS 947



BA 947



BA : Battant



CS : Coulissant

YACHTING



## ANGUILLERS

RAL 7016, 9010, 7035, N 2100

NOUVEAU

BA + CS

**BA / CS 948** - Remplissage lames lisses de 250 x 15 mm, décor ligne aluinox largeur 30 mm.

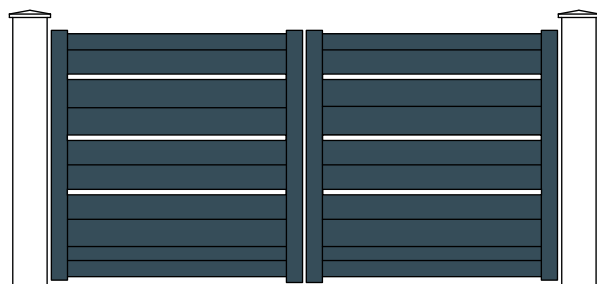

BA 948



CS 948

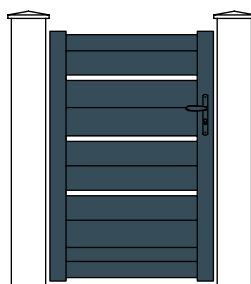

BA 948

### BA / CS 949

Remplissage lames lisses de 250 x 15 mm - Décor carré aluinox plein 120 x 120, ajouré 120 x 120 ou plein avec incrustation bois.



Carrés ajourés 120 x 120 mm

### BA / CS 950

Remplissage lames lisses de 250 x 15 mm - Décor ligne Aluinox largeur 30 mm + aspect bois



BA 950



BA : Battant



CS : Coulissant

YACHTING 

## ANGUILLERS

BA + CS

NOUVEAU

### BA / CS 951

Remplissage lames lisses de 250 x 15 mm - Décor carré aluinox avec volcan ou corten et noir infini



BA 951

### BA / CS 952

Remplissage lames lisses de 250 x 15 mm - Décor aluinox



BA 952

## SARTHE

BA + CS

Remplissage lames lisses 163 x 25 mm

NOUVEAU

Spécial en bois ou en ajouré

### BA 957 / CS 957



BA 957 - Spécial - ajouré



BA 957 - Spécial - bois



BA : Battant



CS : Coulissant



CB : Coulissant aspect Battant

YACHTING



## ACCORE - "S" horizontal

Remplissage lames lisses 163 x 25 mm

BA + CS

NOUVEAU

BA / CS 958

Option : Simple "S" horizontal

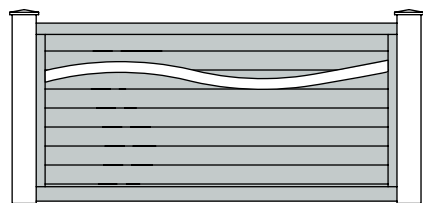

CS 958

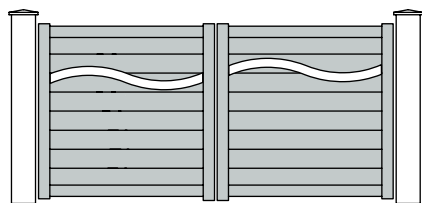

BA 958

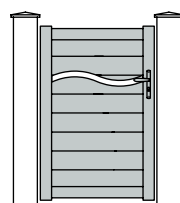

BA 958

Option : Double "S" horizontal

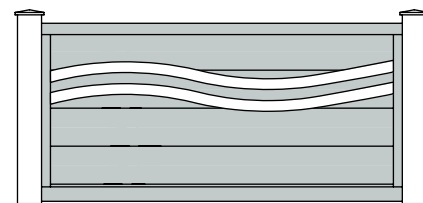

CS 958

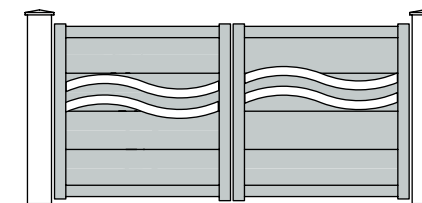

BA 958

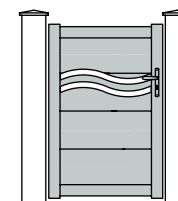

BA 958



Portail BA 958 - simple «S» horizontal



Portail BA 958 - double «S» horizontal



BA : Battant



CS : Coulissant

YACHTING 

## LA CIBLE

NOUVEAU

BA + CS

Remplissage lames lisses 163 x 25 mm

BA 967 / CS 967



BA 967 - Zoom sur cible



BA 967





BA : Battant



CB : Coulissant  
aspect Battant

YACHTING



## SPINNAKER

NOUVEAU

BA + CB

Remplissage lames lisses 163 x 25 mm

BA / CS 968

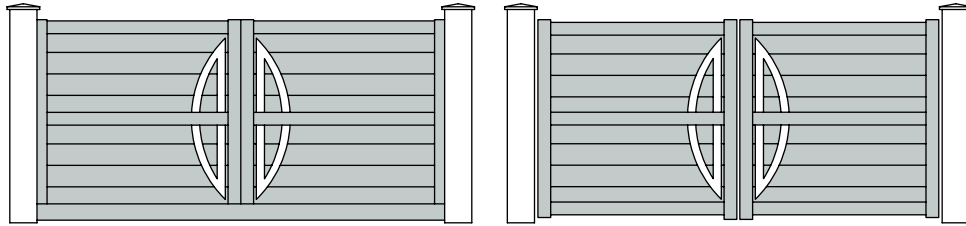

CB 968

BA 968

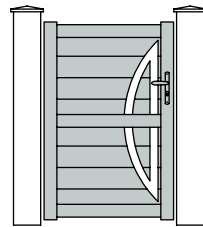

BA 968



Option : modèle avec 1 seul Arc

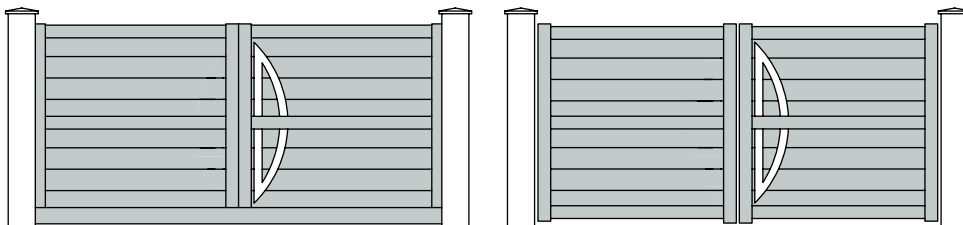

CB 968

BA 968

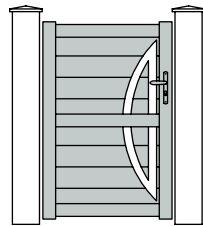

BA 968

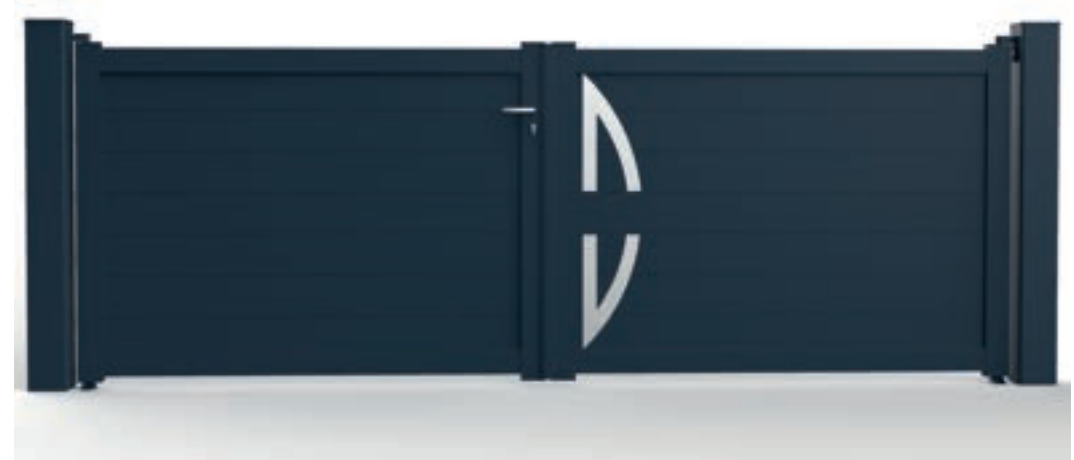



BA : Battant



CS : Coulissant

YACHTING



## LA FLEUR

BA + CS

Remplissage lames lisses 163 x 25 mm

NOUVEAU

BA 977 / CS 977



Modèle BA 977

Zoom Fleur



## GOELAND

RAL 7016, 9010, 7039, N 2100  
& Noir Bazalt

NOUVEAU

BA + CS

BA / CS 978 - Remplissage lames lisses de 300 x 25 mm,  
décor ligne Aluinox largeur 30 mm.



BA 978



CS 978

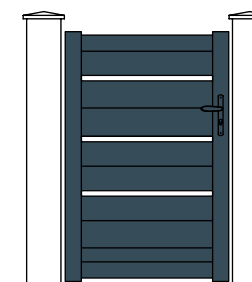

BA 978





BA : Battant



CS : Coulissant

YACHTING



## GOELAND

RAL 7016, 9010, 7039, N 2100 & Noir Bazalt

NOUVEAU

BA + CS

### BA / CS 979

Remplissage lames lisses de 300 x 25 mm - Décor carré aluinox plein 120 x 120, ajouré 120 x 120 ou plein avec incrustation bois.



Carrés ajourés 120 x 120 mm

### BA / CS 980

Remplissage lames lisses de 300 x 25 mm - Décor ligne Aluinox largeur 30 mm + aspect bois



BA 980

### BA / CS 981

Remplissage lames lisses de 300 x 25 mm - Décor carré aluinox avec volcan ou corten et noir infini



BA 981

### BA / CS 982

Remplissage lames lisses de 300 x 25 mm - Décor aluinox



BA 982



BA : Battant



CS : Coulissant

YACHTING



## IN LOVE STREET ART

BA + CS

Lames 163 x 25

BA 987 / CS 987



BA 987 - In Love Street Art

Zoom





BA : Battant



CB : Couissant  
aspect Battant

YACHTING



## DEUX ÉTOILES

BA + CB

Lames 163 x 25

Rugby : au couleur de votre stade préféré

**BA 988 / CS 988**

## PASSION

BA + CB

Lames 163 x 25

Décor de moto, voiture, emblème de région... Choix sur demande.

**BA 998 / CS 998**





Portail BAF 522 avec option tôle de festonnage  
et pointes fer de lance en vert 6005G



**BAF** : Battant



**CBF** : Couissant  
aspect Battant

Traverse 50%  
+ potelet (sauf CBF 501)

**FORGERON**



## CHINON + clôture

RAL 7016

**NOUVEAU**

BAF + CBF

Modèle sans pointes. Barreaux de 20 x 23,5 mm, tôle de 2 mm, bouchon plastique Noir. Uniquement en Ral 7016

**BAF 500 / CBF 500**



BAF 500

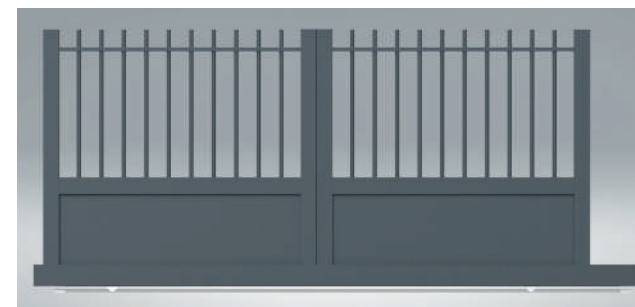

CBF 500



CL 500

**STANDARD :**

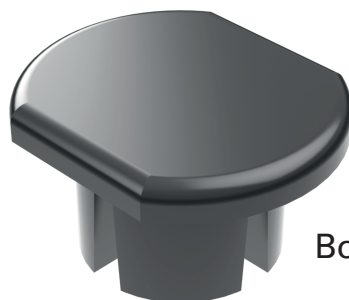

Bouchon plastique Noir

**OPTION TOLE :**

Remplissage riveté derrière les barreaux :

- soit rectangulaire
- soit aspect festonné



**BAF** : Battant



**CBF** : Coulissant  
aspect Battant

Traverse 50%  
+ potelet (sauf CBF 501)

**FORGERON**



## SENLIS

BAF + CBF



BAF / CBF 501



BAF / CBF 510

Portail CBF 510 avec option tôle de festonnage



Portail CBF 522 avec option tôle de festonnage

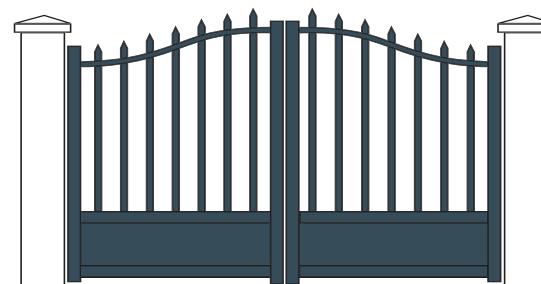

BAF / CBF 522

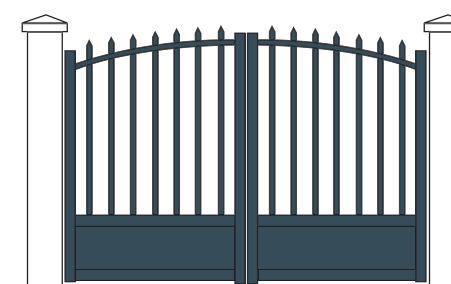

BAF / CBF 521



**BAF : Battant**



**CBF : Couissant  
aspect Battant**

Traverse 50%  
+ potelet (sauf CBF 501)

**FORGERON**



## CHAMBORD + clôture

RAL 7016

**NOUVEAU**

BAF + CBF

Modèle sans pointes. Barreaux de 20 x 23,5 mm, tôle de 2 mm, bouchon plastique Noir. Uniquement en Ral 7016

**BAF 600 / CBF 600**

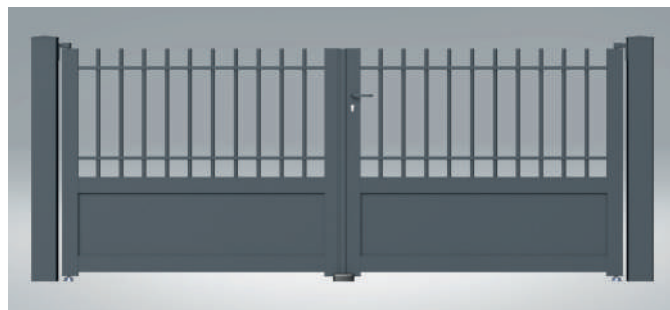

BAF 600

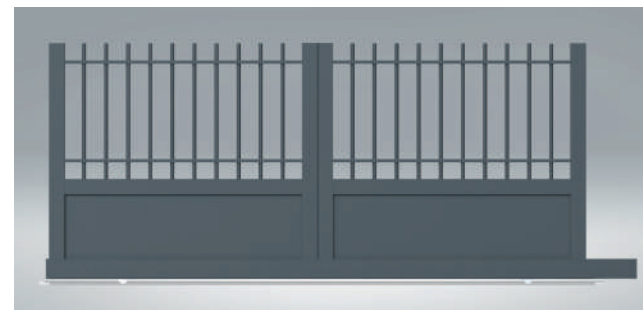

CBF 600



CL 600

**STANDARD :**

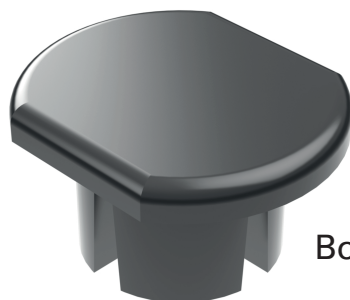

Bouchon plastique Noir

**OPTION TOLE :**

Remplissage riveté derrière les barreaux :

- soit rectangulaire
- soit aspect festonné



**BAF** : Battant



**CBF** : Couissant  
aspect Battant

Traverse 50%  
+ potelet (sauf CBF 501)

**FORGERON**



## CHANTILLY

BAF + CBF



Portail CBF 622 avec option tôle de festonnage et anneaux

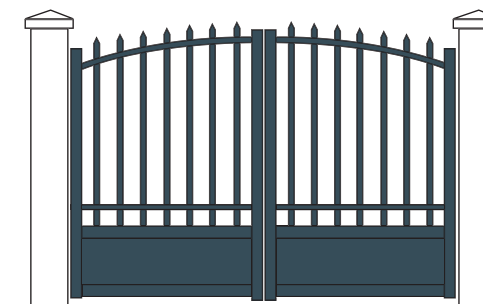

BAF / CBF 621

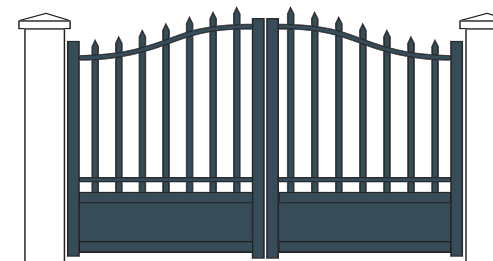

BAF / CBF 622



BAF / CBF 601



BAF / CBF 610



BAF 610 avec palmettes - Option tôle de festonnage





**BAF** : Battant



**CBF** : Coulissant  
aspect Battant

Traverse 50%  
+ potelet (sauf CBF 501)

**FORGERON**



## FONTAINEBLEAU

BAF + CBF



BAF / CBF 722



BAF / CBF 721



BAF / CBF 701

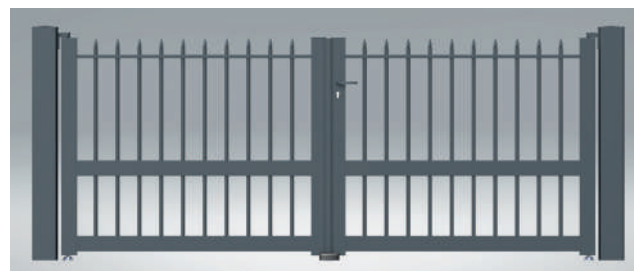

BAF / CBF 710



Portail BAF 821



**BAF** : Battant



**CBF** : Couissant  
aspect Battant

Traverse 50%  
+ potelet (sauf CBF 501)

**FORGERON**



## VERSAILLES

BAF + CBF



BAF 822 avec Anneaux et pointes Fer de Lance



BAF / CBF 821



BAF / CBF 822



BAF / CBF 801



BAF / CBF 810





Portail BAF 710



BAF 522 avec option festonnage



BAF : Battant



CBF : Coulissant  
aspect Battant

FORGERON



## ACCESSOIRES DÉCORATIFS

BAF + CBF + CLF

OPTIONS



BAF 501 avec tôle de festonnage

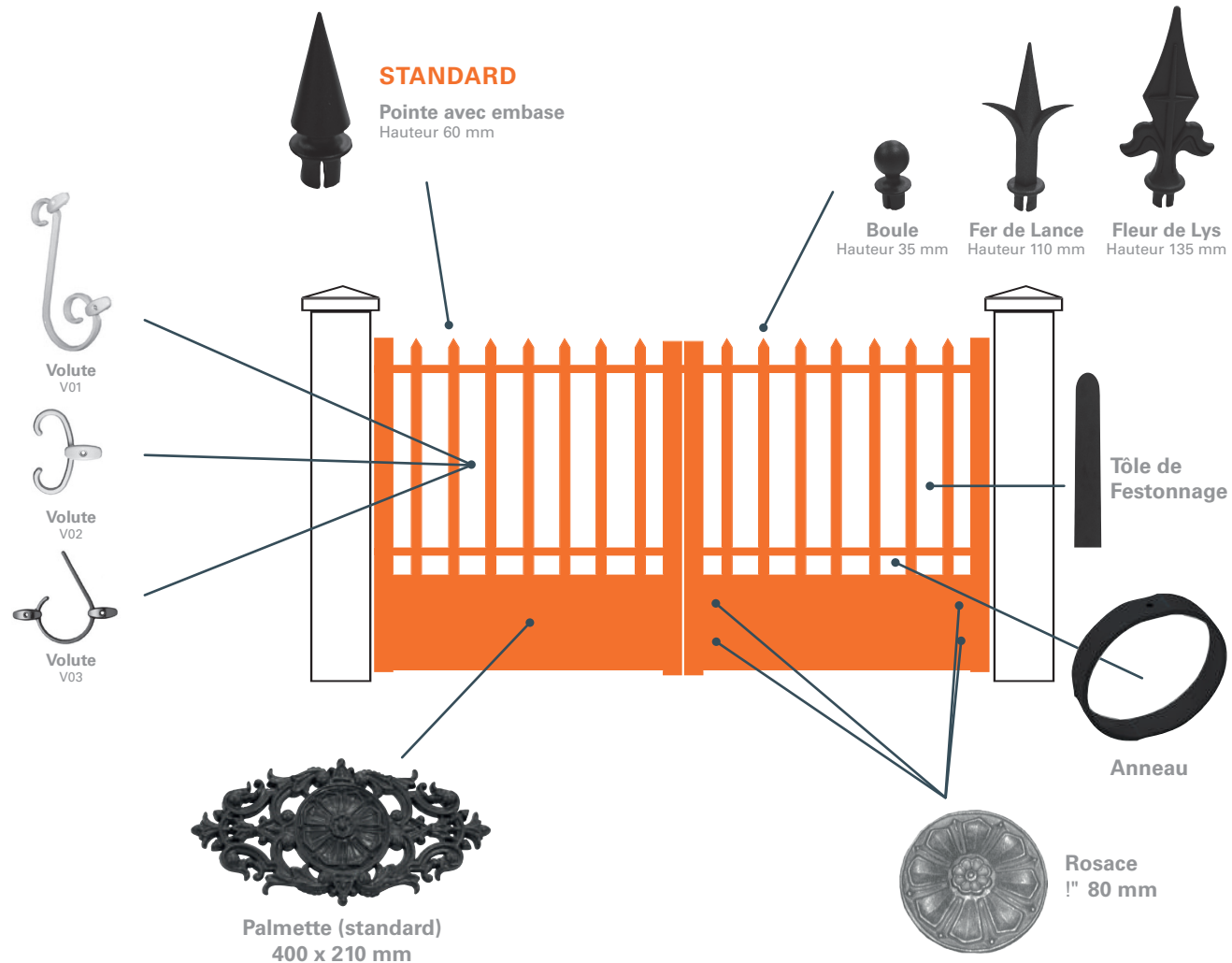

Accessoires laqués en Noir pour les coloris hors standard  
sauf sur demande, veuillez nous consulter.

OSEZ LE VÔTRE



### L'aluminium : matériau recyclable

En effet il est 100% recyclable, sans perte de ses qualités physico-chimiques.



### Durabilité et assemblage

L'assemblage de nos portails est réalisé par emboîtement des profils sur 65 mm pour les portails battants et 20 mm pour les coulissants afin d'obtenir une résistance maximale.

L'ensemble est vissé par des vis inox.



### Structure et design

Les profilés constitutifs de nos portails sont de forte section, ce qui confère : solidité et esthétique.

## COTES DES PROFILÉS CLUB



	BA	CS	CB(F)		BA	CS	CB(F)
<b>Montant</b>	94 x 53 mm	94 x 49 mm	94 x 53 mm	<b>Remplissage lisse</b>	21 x 25 mm	16 x 25 mm	X
<b>Traverse haute</b>	94 x 49 mm	94 x 91 mm	94 x 49 mm		163 x 25 mm	163 x 25 mm	163 x 25 mm
<b>Traverse haute Ferro</b>	20 x 40 mm	X	20 x 40 mm	<b>Remplissage trapèze</b>	250 x 15 mm	250 x 15 mm	X
<b>Traverse intermédiaire</b>	94 x 49 mm	94 x 37 mm	94 x 49 mm		300 x 25 mm	300 x 25 mm	X
<b>Traverse basse</b>	94 x 49 mm	120 x 59 mm	120 x 59 mm	<b>Remplissage Tôle</b>	128 x 25 mm	128 x 25 mm	X
<b>Barreau</b>	25 x 25 mm	25 x 25 mm	X		160 x 25 mm	160 x 25 mm	X
	50 x 25 mm	50 x 25 mm	X	<b>Remplissage Wood</b>	Épaisseur 2 mm	Épaisseur 2 mm	Épaisseur 2 mm
	92 x 25 mm	92 x 25 mm	92 x 25 mm		Épaisseur 6 mm	Épaisseur 6 mm	X
<b>Barreau Ferro</b>	20 x 23,7 mm	X	20 x 23,7 mm	<b>Lame porte tôle trapèze</b>	80 x 25 mm	80 x 25 mm	X
<b>Remplissage lisse avec liseret</b>	163 x 25 mm	163 x 25 mm	X	<b>Lame porte tôle lisse</b>	81,7 x 25 mm	81,7 x 25 mm	X

Nos thermolaquages (projection de poudre à haute pression sur les profils aluminium, puis cuisson au four) sont garantis 25 ans sur CLUB COLOR et 10 ans sur autres finitions et bénéficient du label QUALICOAT et QUALIMARINE.

Laquage qualité QUALICOAT, représentation des couleurs et des textures non contractuelle.

La garantie 25 ans couvre exclusivement les profilés laqués (à l'exclusion de tous accessoires et tôles) contre les défauts suivants : farinage, changement de teinte et perte de brillance supérieurs aux tolérances des prescriptions du label QUALICOAT.

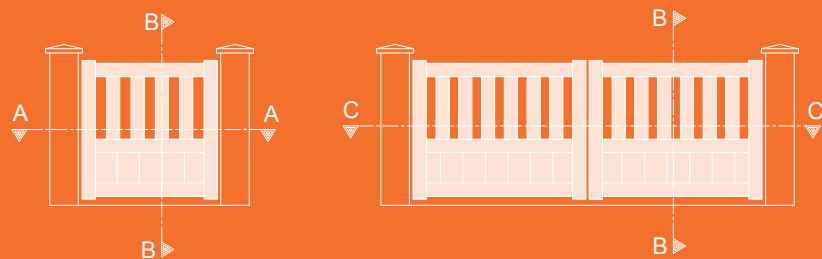

## Coupe A-A

Réception portillon standard sur gâche

## NOUVEAU

Joint d'occultation

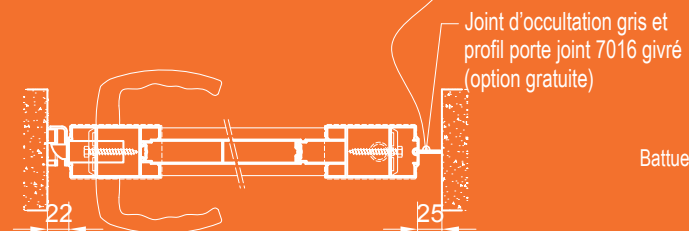
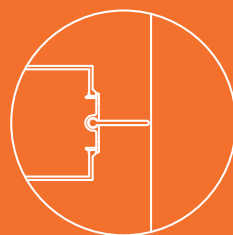

Réception portillon avec battue (option)

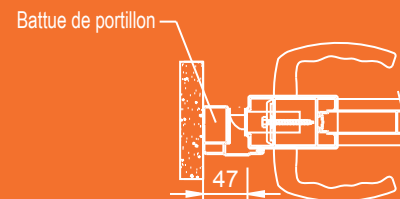

## Coupe C-C

Prise de côte : entre poteaux

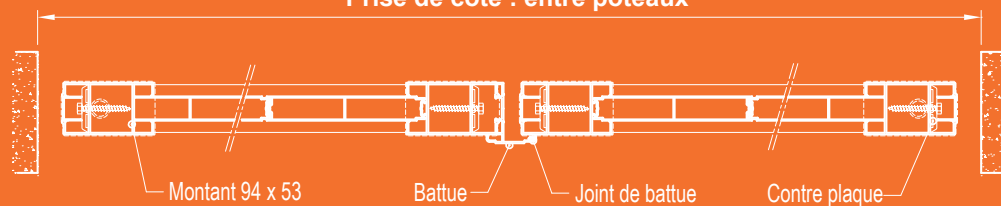

## Coupe B-B

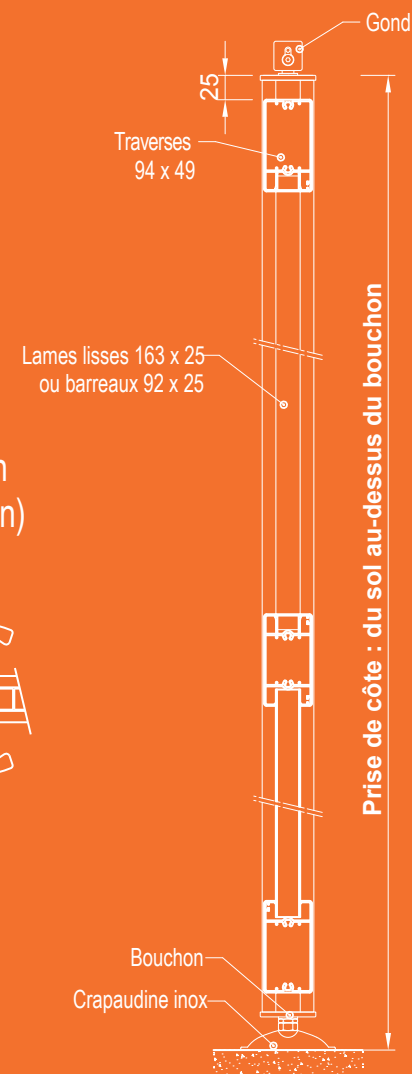



# BATTANT

## GAMME CLUB



### Les composants

### Les options supplémentaires

#### Régulateur de pente

Accessoires laqués en Noir pour les coloris hors standard sauf sur demande, veuillez nous consulter.



#### Pattes à 180°



Normales

Renforcées



Gâche électrique

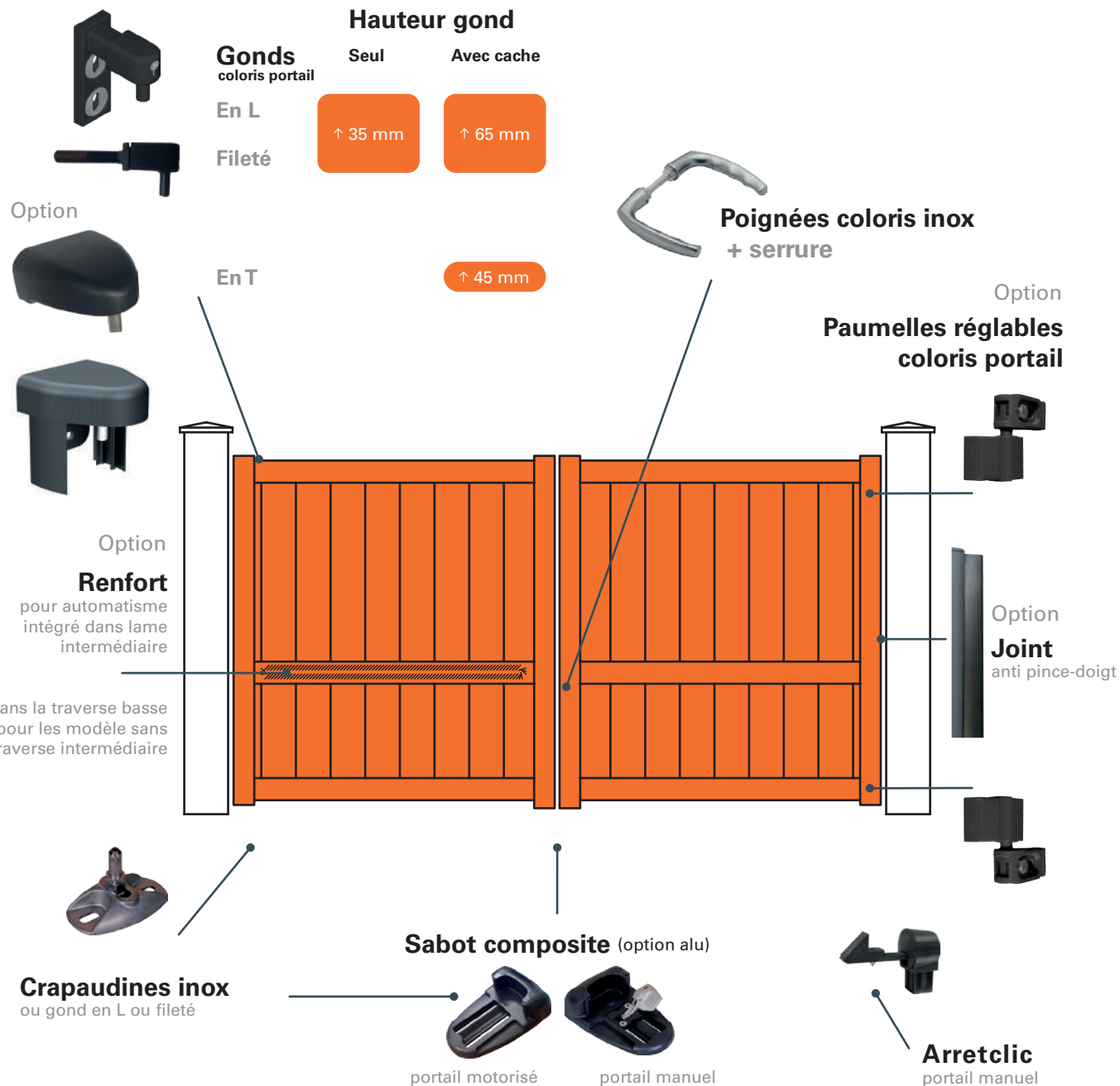

# NOUVEAU

Joint brise vue

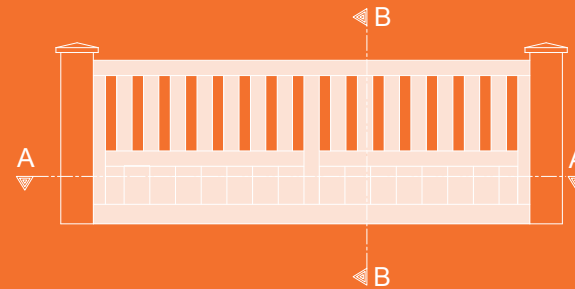
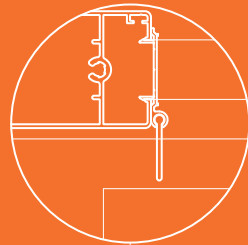

## Coupe A-A

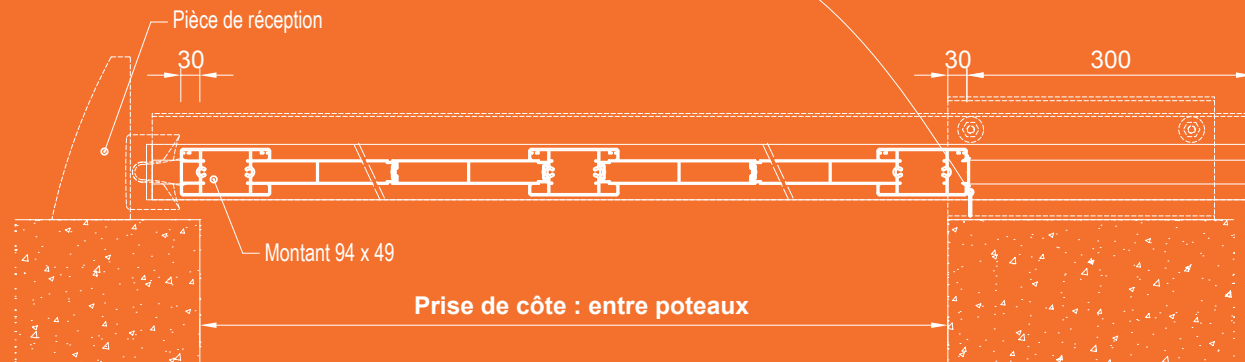

## Coupe B-B

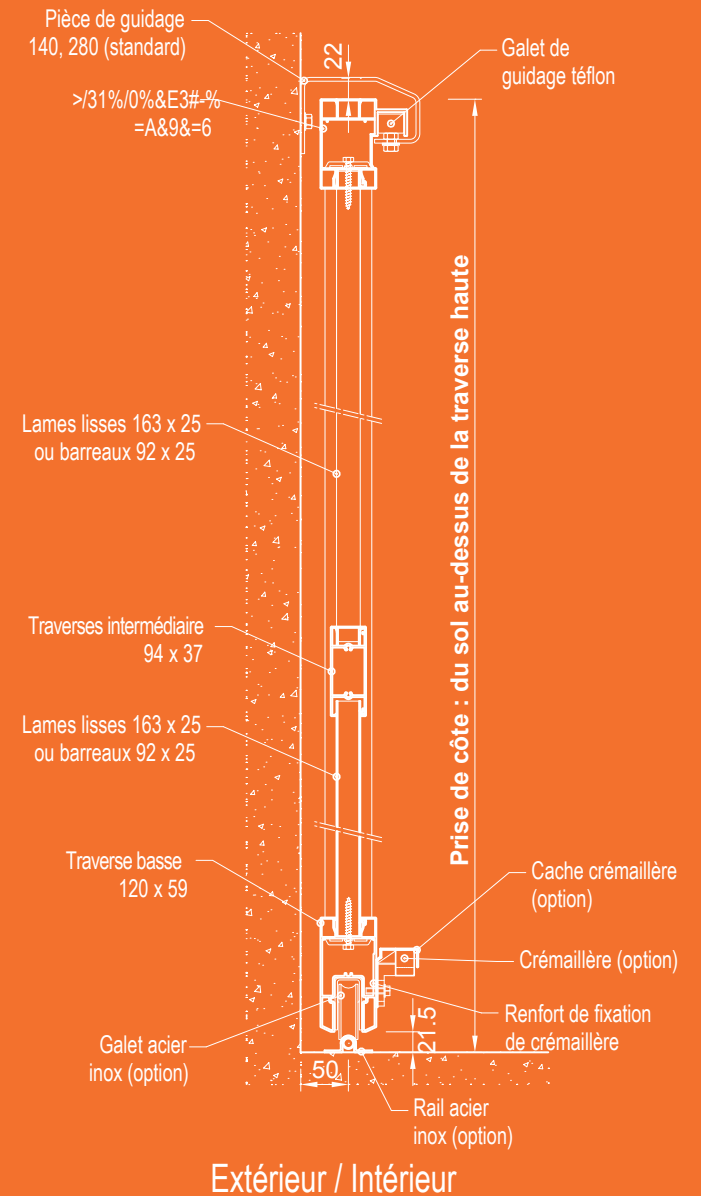

# COULISSANT

## GAMME CLUB

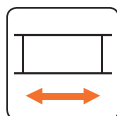

### Les composants

### L'option supplémentaire

Longueur : 280 (standard)  
140 (option)

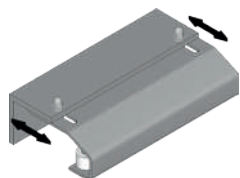

Accessoires laqués en Noir pour les coloris hors standard  
sauf sur demande, veuillez nous consulter.

### Poignées coloris inox

+ serrure

Poignée réduite en extérieur

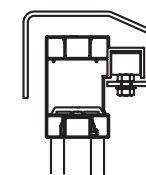

### Pièce de guidage réglable coloris portail

Hauteur : ↑ 34 mm  
Longueurs : 280 (standard)  
140 (option)

### Pièce de réception coloris portail

Portail fermé

### Renfort

pour auto-  
matisme  
intégré dans  
la traverse  
basse

### Option Pièce de réception coloris portail

Portail ouvert

### Butée

### Rail acier option inox



### Option Crémaillère avec ou sans cache



### Galets acier avec bandage polyamide antibruit

option inox (pas de bandage)



# NOUVEAU

Joint brise vue

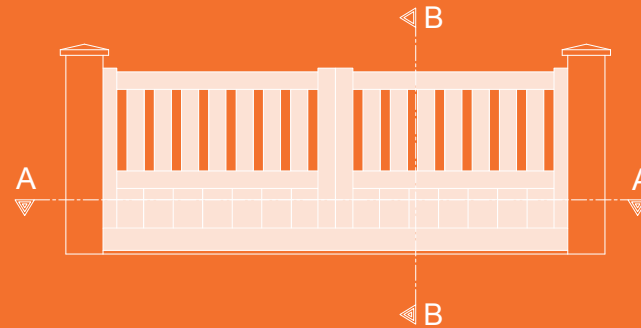
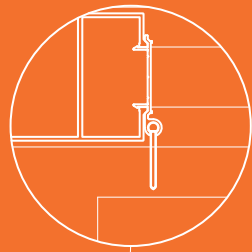

## Coupe A-A

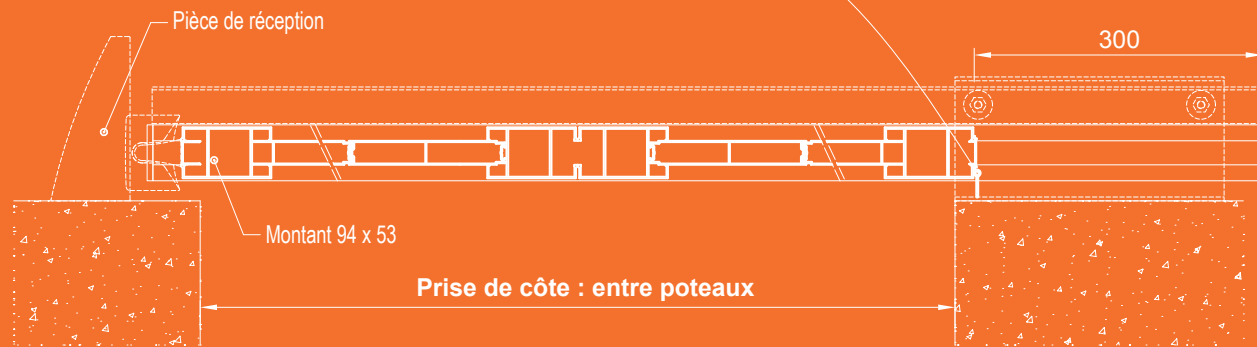

## Coupe B-B

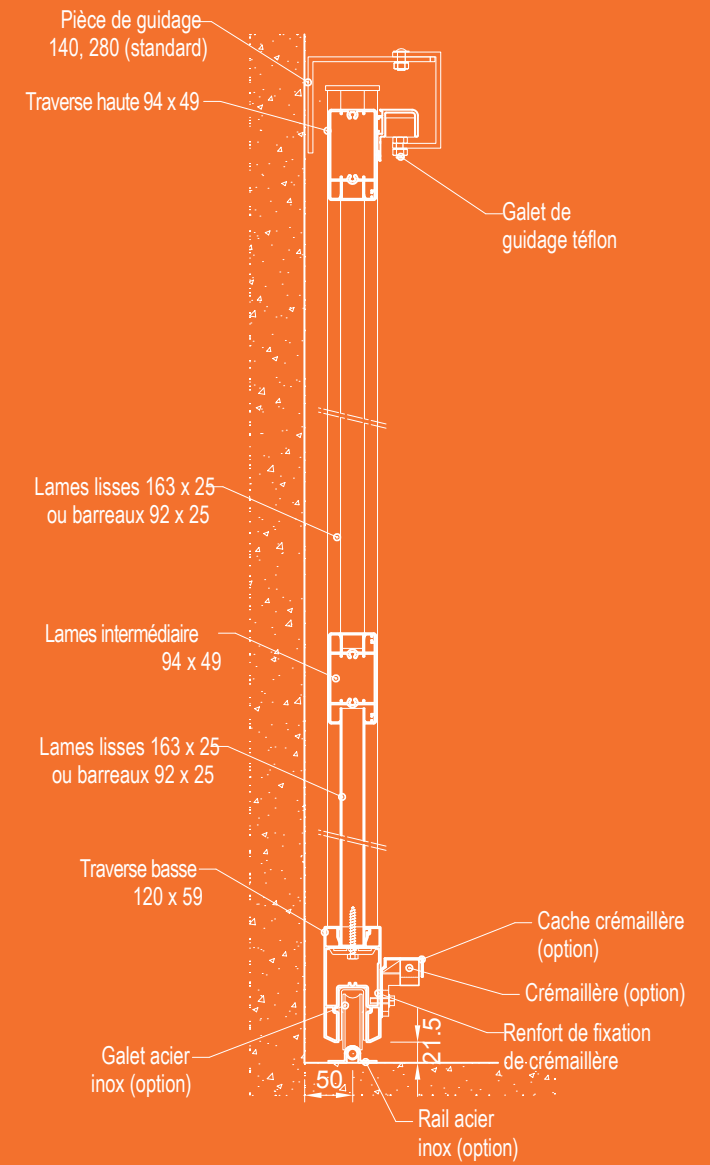

Extérieur / Intérieur

Closura se réserve le droit de modifier le design, les côtes des profilés et des accessoires.

# COULISSANT ASPECT BATTANT

GAMME CLUB

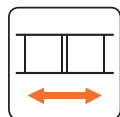

## Les composants

### Poignées coloris inox

+ serrure

Poignée réduite en extérieur



### Pièce de guidage réglable coloris portail

Hauteur : ↑ 34 mm  
Longueurs : 280 (standard)  
140 (option)

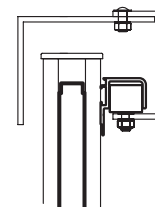

### Pièce de réception coloris portail

Portail fermé

### Renfort

pour auto-  
matisme  
intégré dans  
la traverse  
basse

### Rail acier option inox



### Option Crémaillère avec ou sans cache



### Galets acier avec bandage polyamide antibruit

option inox (pas de bandage)



### Option Pièce de réception coloris portail

Portail ouvert

### Butée



Accessoires laqués en Noir pour les coloris hors standard  
sauf sur demande, veuillez nous consulter.

# Coupe B-B

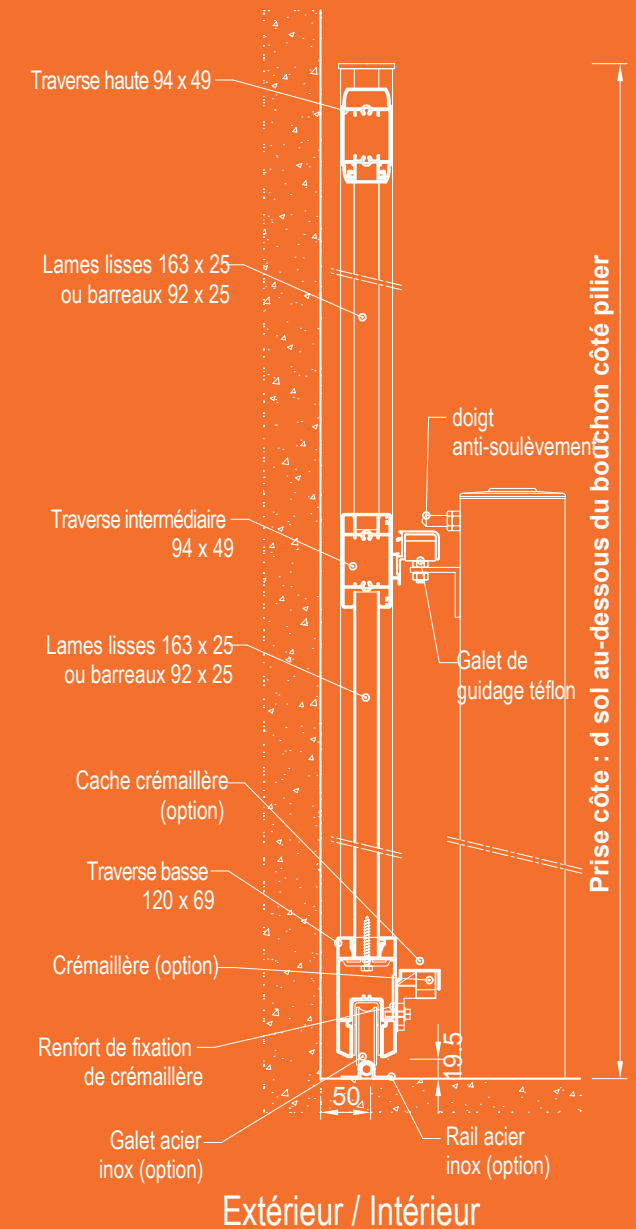

## Choix des Potelets

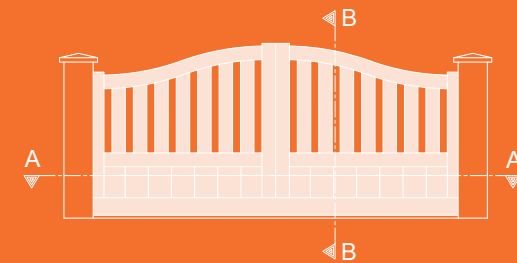
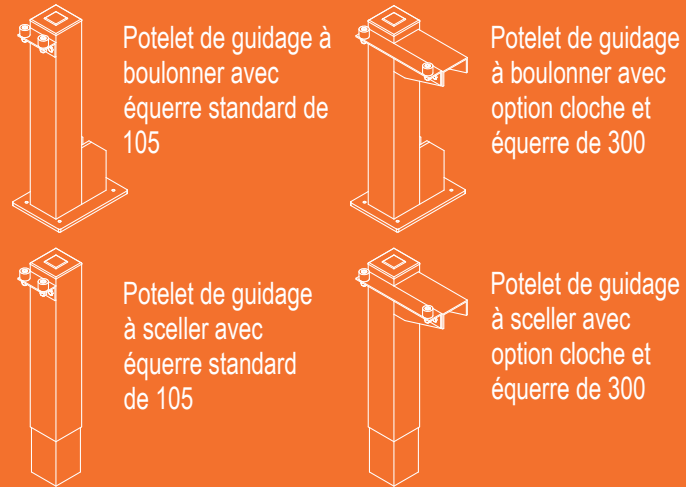

## NOUVEAU

Joint brise vue

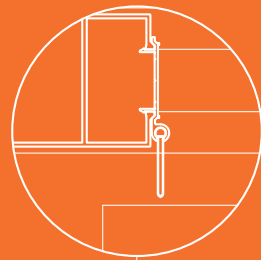

## Coupe A-A

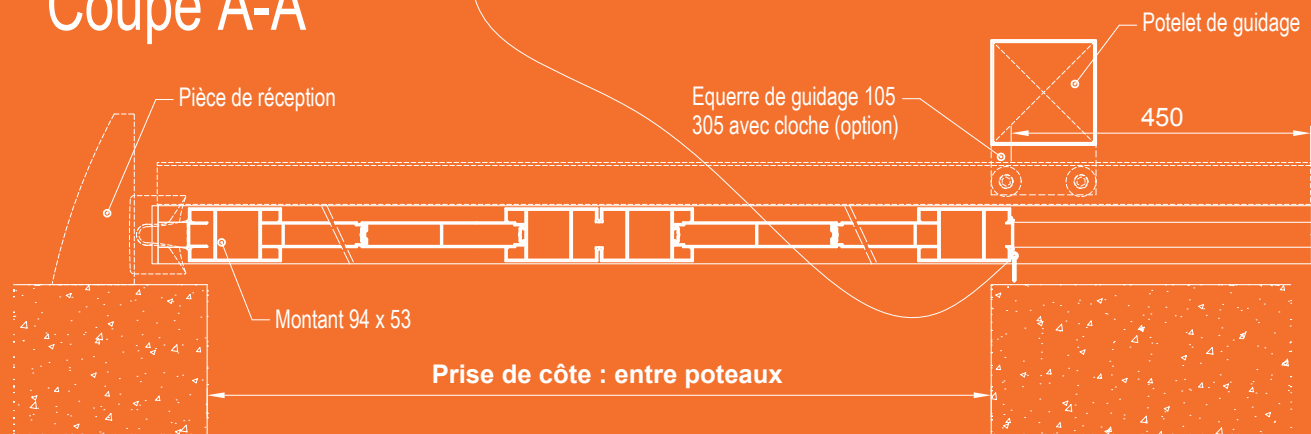

# COULISSANT ASPECT BATTANT TRAVERSE EN FORME

GAMME CLUB

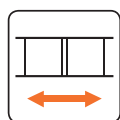

## Les composants

### Poignées coloris inox

+ serrure

Poignée réduite en extérieur

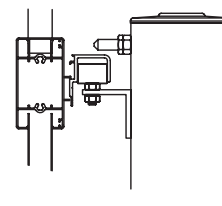

### Équerre de guidage réglable sur potelet coloris : Closura Colors

- 105 (standard)  
- 305 renforcée (option)

Option  
Pièce de  
réception  
coloris  
portail

Portail ouvert



Butée



Pièce de  
réception  
coloris  
portail

Portail fermé

Renfort

pour auto-  
matisme  
intégré dans  
la traverse  
basse

Rail acier  
option inox



Option  
Crémaillère avec ou  
sans cache



Galets acier avec  
bandage polyamide  
antibruit

option inox (pas de bandage)



Accessoires laqués en Noir pour les coloris hors standard  
sauf sur demande, veuillez nous consulter.

**NOUVEAUTÉ**

# COULISSANT AUTOPORTANT

## GAMME CLUB

Tout RAL Club color sauf N Bazalt et brun 477

- Gain en maçonnerie car la longrine est évitée, seul un gros plot en béton sera nécessaire
- Gravillons, terre, feuilles, etc. ne seront pas gênants
- Les braquages fréquents de roue sur le rail ne seront plus proscrits
- La continuité du sol sera maintenue : graviers, pavés, pelouse, etc.
- Pièce de guidage au RAL du portail
- Pièce de réception en Inox
- Bouchon de traverse basse en Nylon Noir.

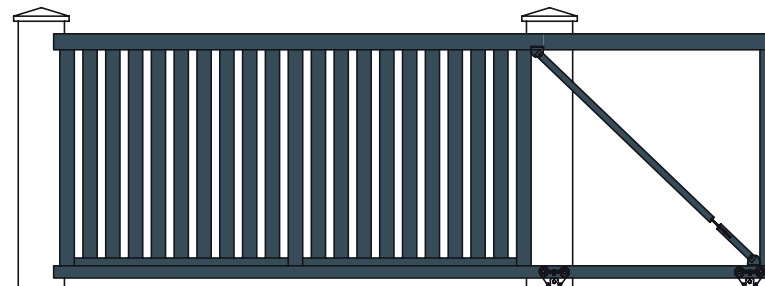

### CSA 3101 : Barreaux

À l'identique du CS 101 Gamme CLUB, barreaudage vertical - hauteur maximum 2,00 mètres



Portail CSA 3111





## FREE CROSSING - USAGE RÉSIDENTIEL

Suppression du rail au sol, manuel ou motorisé, sur une poutre basse dédiée en aluminium.

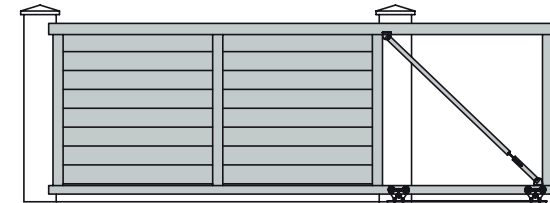

**CSA 3208 : Lames droites**

À l'identique du CS 208 Gamme CLUB, lames pleines horizontales - hauteur maximum 2,00 mètres

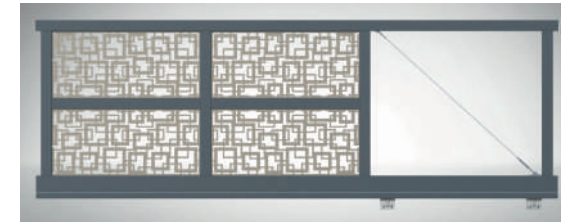

**CSA 3261**



**CSA 3311**

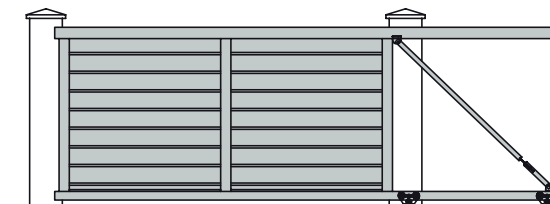

**CSA 3408 : Lames trapèzes**

À l'identique du modèle CS 408 Gamme LINE, lames trapèze horizontales IN & OUT - hauteur maximum 2,00 mètres

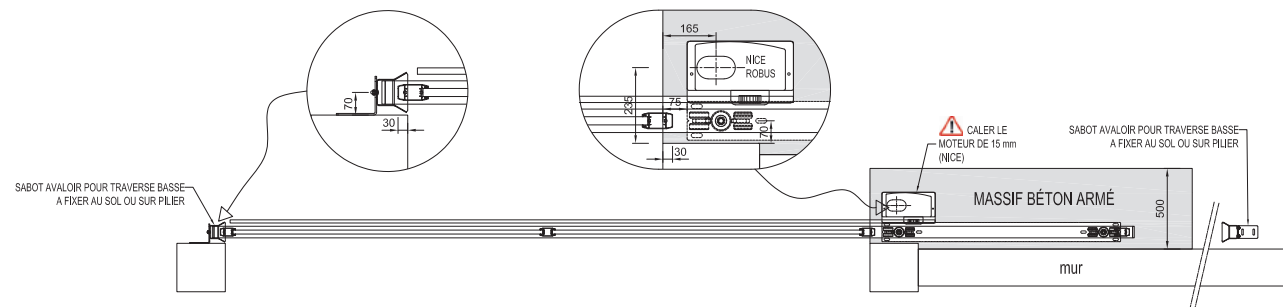

---

# COULISSANT FACE À FACE

NOUVEAUTÉ

GAMME CLUB

Portail CBF 622 en manoeuvre FACE à FACE



Portail CB 2408 en manoeuvre FACE à FACE



NOUVEAUTÉ

# NOS PORTAILS PERSONNALISÉS

GAMME CLUB



Portail CS 311 avec portillon intégré



Portail CS 408 très grande longueur avec tôle brindille